

Sliding Modes Observers for Estimation of Performance of Heavy Vehicles

N. M'Sirdi, A Boubezoul, A. Rabhi, L. Fridman

► **To cite this version:**

N. M'Sirdi, A Boubezoul, A. Rabhi, L. Fridman. Sliding Modes Observers for Estimation of Performance of Heavy Vehicles. 3rd International Conference on Advances in Vehicle Control and Safety (AVCS 2007), Feb 2007, Buenos Aires, Argentina., Feb 2007, Buenos Aires, Argentina. pp.313-318. hal-01966657

HAL Id: hal-01966657

<https://hal-amu.archives-ouvertes.fr/hal-01966657>

Submitted on 29 Dec 2018

HAL is a multi-disciplinary open access archive for the deposit and dissemination of scientific research documents, whether they are published or not. The documents may come from teaching and research institutions in France or abroad, or from public or private research centers.

L'archive ouverte pluridisciplinaire **HAL**, est destinée au dépôt et à la diffusion de documents scientifiques de niveau recherche, publiés ou non, émanant des établissements d'enseignement et de recherche français ou étrangers, des laboratoires publics ou privés.

Sliding Modes Observers for Estimation of Performance of Heavy Vehicles

N. K. M'Sirdi¹, A. Boubezoul¹, A. Rabhi¹ and L. Fridman²

Abstract—The main objective of this work, is to improve performance handling or maneuverability, by means of the observation of vehicle dynamics in order to obtain safer and an easier driving. A nominal model is proposed to describe the nonlinear dynamic of a tractor and semi-trailer vehicle. The model is developed for the case of cornering manoeuvre at constant speed. First and second order sliding mode observers are developed to estimate the vehicle state. Input lateral forces are estimated in a last step. We focus our work to on-line observation of the system states variables and estimation of the lateral tires forces of heavy vehicles. Simulation results are compared to validate the approach.

Keywords: Heavy Vehicle Modeling, Sliding Mode Observers, First and second order sliding modes, Estimation of contact forces, unknown input observer.

I. INTRODUCTION

The work presented in this paper has been done in the context of the national french project ARCOS 2004. The main objective is to develop predictive procedures allowing to detect risky situations and produce alarms.

A large number of car accidents is attributed by statistic studies to increase of presence of heavy vehicles. Statistics on trucks accidents was performed to analyze the road accidents [1]. For the accidents involving at least one truck, the truck is alone in 33 % of the cases. These accident can be divided into three types : 20 % rollover, 11 % the road departure and 2 % jackknifing. The truck structure often concerned by these accidents is the tractor vehicle and the semi trailer. This type of truck is involved for: 45 % of the trucks in the whole database, and 80 % of those involved in a rollover.[1]

Truck accidents occur for several reasons involving components of driver-vehicle-environment system. Such situation occurs when the vehicle is driven beyond the stability limits [2]. However more and more new active safety systems are developed and installed on vehicle for real-time monitoring and controlling the dynamic stability (EBS, ABS, ESP). Nevertheless, the possibility of rectifying an unstable condition can be compromised by physical limitations. Therefore, it is extremely important to detect on time a tendency towards instability [3]. This requires well understanding and revisiting vehicles dynamic stability [2].

In literature, several procedures have been proposed to detect instabilities in the vehicle dynamics [4] [5] [6] [7].

¹LSIS, CNRS UMR 6168. Dom. Univ. St Jérôme, Av Escadrille Normandie-Niemen 13397 Marseille France; msirdin@lsis.org

²UNAM Dept of Control, Division of Electrical Engineering, Faculty of Engineering, Ciudad Universitaria, Universidad Nacional Autónoma de México, 04510, México, D.F., México

⁰ARCOS 2004 is supported by CNRS, ministry of research and education and ministry of equipment of the french government.

In general lateral slips, over steering or roll over situations are detected by means of measurements processing. Other methods use measurements combined with some dynamic model of the vehicle.

The main information needed to prevent risky situations, by efficient prediction, are the vehicle states and input contact forces. This knowledge is necessary for forward prediction of the system's behavior and preview control or safe monitoring.

In this paper, we focus our work to the on-line estimation of the lateral tires forces of heavy vehicle in a cornering manoeuvre at constant speed (without breaking and acceleration).

The organization of this paper is as follows. In second section, we develop a simplified model describing the behavior of heavy vehicle. The dynamics equations are deduced by Lagrangian approach assuming a cornering manoeuvre at constant velocity. Two observers are designed in section 3. The first one is based on first order sliding mode approach and backstepping to estimate the system state and then using the results we deduce the applied tire forces. The second observer uses the super twisting algorithm (second-order sliding mode) to observe states and then identify or estimate the tires forces. The section 4 will discuss the simulation results and validation. A conclusion is given to emphasize interest of these results for predictive diagnosis giving embedded help systems for safe driving.

II. NONLINEAR HEAVY VEHICLES NOMINAL MODEL

A. Vehicle Description and motions

The type of heavy vehicle considered in this work is a tractor-semi-trailer with 5-axels (as shown by the scheme of figure 1). In order to estimate the essential dynamics in a cornering manoeuvre, we adopt a simple configuration to describe our heavy vehicle [8]. The tractor has a body with 2-axels and the attached semi-trailer is made of a body supported by 3 grouped axels.

To deduce the model of heavy vehicle, we consider the following assumptions for simplification.

·The pitch and bounce dynamics may be neglected, tractor and trailer are considered as rigid bodies. Only dynamics of two bodies (i.e. tractor and trailer's chassis) are considered.

·The total suspension motions are reduced to the roll of suspension axels only. The pitch and bounce motions are neglected.

·The essential dynamics considered here are the yaw and horizontal translation motions, the tractor roll angle and articulation angle between the tractor and trailer (see figure 2). The trailer's roll angle is measured around the tractor roll axis.

The dynamics equations of the motion of the two sprung masses is written in a coordinate reference frame

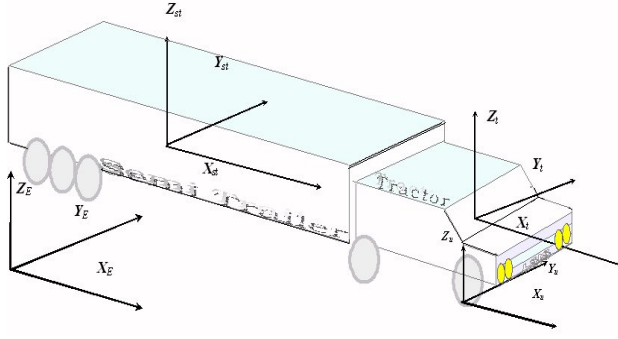

Fig. 1. Tractor and semi-trailer vehicle (components);
Coordinates and reference frames

The System

$\mathcal{R}_E(X_E Y_E Z_E)$ attached to the earth (see figure 1). The frames $\mathcal{R}_T(X_t Y_t Z_t)$ and $\mathcal{R}_{ST}(X_{st} Y_{st} Z_{st})$ are attached to the gravity centers of the tractor and semi-trailer's sprung masses (respectively). $(X_u Y_u Z_u)$ is the frame of tractor's unsprung mass (fixed at center of the front axle with Z_u is parallel to Z_E , see figure 2).

The relative motion of $(X_u Y_u Z_u)$ with respect to the earth-fixed frame $(X_E Y_E Z_E)$ is the horizontal translation of the tractor and its yaw motion around the Z_E axis.

The roll motion is described by motion of $(X_t Y_t Z_t)$ relative to the coordinate $(X_u Y_u Z_u)$. The articulation between the tractor and trailer is described by relative motion of $(X_t Y_t Z_t)$ with respect to the coordinate $(X_t Y_t Z_t)$.

With this coordinate systems and description of their relative motion, we consider the following generalized coordinates:

- x_E : position of the tractor gravity center in \mathcal{R}_E ,
- y_E : position of the tractor gravity center in \mathcal{R}_E ,
- ψ : yaw angle of the tractor,
- ϕ : roll angle,
- ψ_f : angle between tractor and trailer (relative pitch).

B. Nominal dynamics equation

To obtain the dynamics equations of simplified heavy vehicle we use Lagrangian mechanics. The vehicle motion of each body can be expressed using the kinematics of the different references frames defined. The total kinetic energy (E_K) and potential energy (E_P) are expressed in the frame $\mathcal{R}_E(X_E Y_E Z_E)$. The Lagrange approach leads to the following vehicle model [2]:

$$\begin{aligned} \frac{d}{dt} \left(\frac{\partial E_K}{\partial \dot{q}_i} \right) - \frac{\partial E_K}{\partial q_i} + \frac{\partial E_P}{\partial q_i} &= F_{g_i} \\ M(q)\ddot{q} + C(q, \dot{q})\dot{q} + G(q) &= F_g \end{aligned} \quad (1)$$

where q_i is the i^{th} generalized coordinate and q is the generalized coordinate vector defined as $q = [x, y, \psi, \phi, \psi_f]$. The matrix $M(q)$ represent the symmetric and positive definite inertia matrix. The vector $C(q, \dot{q})\dot{q}$ gives the Coriolis and Centrifugal forces and $G(q)$ is the gravity force vector [2]. The effects of the last tree axels may be regrouped in one equivalent.

As generalized forces, the vector F_g represents the wheels - road contact forces acting on the system bodies. This vector

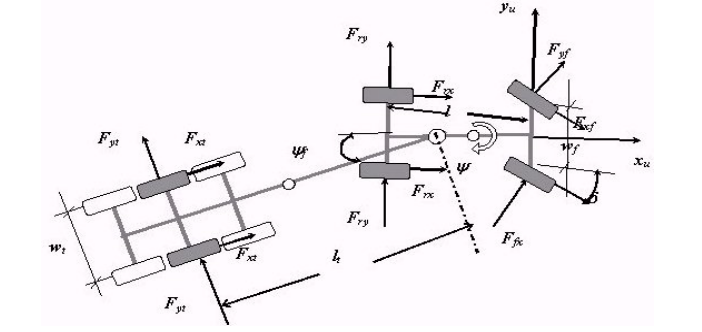
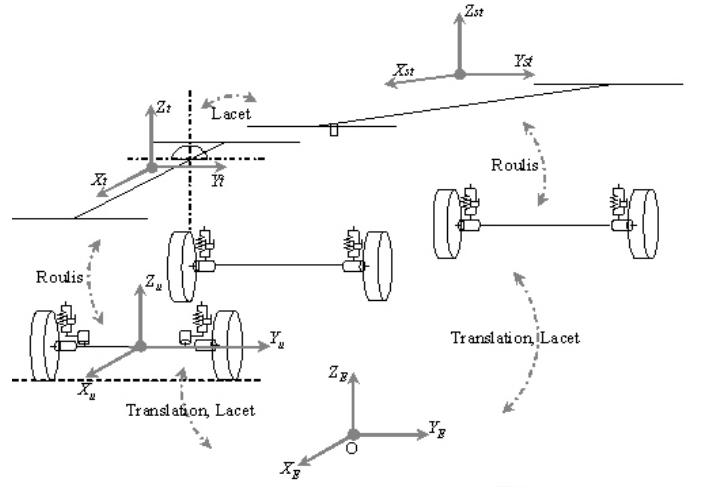

Fig. 2. Applied forces on the tractor and semi trailer vehicle and The Motions of the system parts

is made of vertical, longitudinal and lateral forces due to contact between the wheels and the road (see figure 2) [9]. To link these tires forces and their effects on bodies motion, an extended bicycle model is used [10][2][12].

The tire-road interface forces F_g are related to the suspensions of each wheel through the three axles. Suspensions are modelled as a combination of a spring and a damper elements. Owing to robustness of Sliding Mode approach, with respect to the modeling errors [14][15][16], we use only a simple linear nominal model for suspension.

$$\begin{aligned} F_{sf_i} &= F_{0f_i} + K_f z_{f_i} + D_f \dot{z}_{f_i} \\ F_{sr_i} &= F_{0r_i} + K_r z_{r_i} + D_r \dot{z}_{r_i} \\ F_{st_i} &= F_{0t_i} + K_t z_{t_i} + D_t \dot{z}_{t_i} \end{aligned} \quad \text{for } i = 1, 2 \quad (2)$$

where F_{0_i} is the static equilibrium force and z_i define the deflection of the spring from its equilibrium position with K and D the suspension parameters.

For nominal model, as we consider that the suspension forces are due only to rolling motion, the deflection variables z_i are given as:

$$\begin{aligned} z_{f_1} &= -z_{f_2} = -\frac{w_f}{2} \sin(\phi) \\ z_{r_1} &= -z_{r_2} = -\frac{w_r}{2} \sin(\phi) \\ z_{t_1} &= -\frac{w_t}{2} \sin(\phi) \cos(\psi_r) + l_t \phi \sin(\psi_r) \\ z_{t_2} &= \frac{w_t}{2} \sin(\phi) \cos(\psi_r) + l_t \phi \sin(\psi_r) \end{aligned} \quad (3)$$

To include tire forces in the model, we consider a cornering manoeuvre realized at constant speed. Then, the longitudinal forces are assumed nulls. The total tire/road adhesion is

considered forward the lateral direction (see figure 3). In this model, the unknown inputs are the lateral tire forces at the front and rear axles of the tractor and the one at the semitrailer equivalent (rear) axle. These forces will be represented by the vector $F = (F_f, F_r, F_t)$.

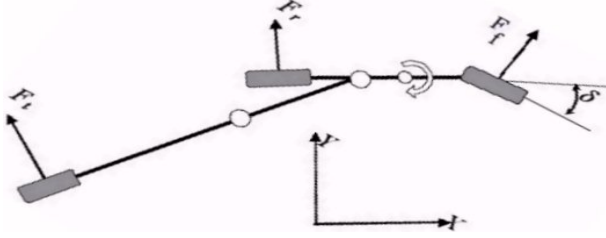

Fig. 3. The extended Bicycle model

The vehicle model (1), developed in the inertial frame, depends on the position and orientation of the vehicle in this reference. However, the measurements used generally in vehicles to analyze the dynamics are defined in the vehicle unsprung mass frame. Then, we will rewrite the vehicle model (1) (inertial reference) with respect to this reference frame (unsprung mass reference frame) using the transformation matrices between those coordinates. Then we obtain the following relations:

$$\begin{aligned} \dot{x}_E \cos(\psi) + \dot{y}_E \sin(\psi) &= v_x \\ -\dot{x}_E \sin(\psi) + \dot{y}_E \cos(\psi) &= v_y \\ \ddot{x}_E \cos(\psi) + \ddot{y}_E \sin(\psi) &= \dot{v}_x - v_y \dot{\psi} \\ -\ddot{x}_E \sin(\psi) + \ddot{y}_E \cos(\psi) &= \dot{v}_y - v_x \dot{\psi} \end{aligned} \quad (4)$$

where \dot{x}_E and \dot{y}_E are respectively the vehicle velocities in the inertial reference frame. v_x and v_y are respectively the vehicle velocity components along the axes X_u and Y_u in the unsprung mass reference frame. The transformation of the generalized forces is obtained in the same way:

$$\begin{aligned} F_x &= F_{g_x} \cos(\psi) + F_{g_y} \sin(\psi) \\ F_y &= -F_{g_x} \sin(\psi) + F_{g_y} \cos(\psi) \end{aligned} \quad (5)$$

where F_x and F_y are the external forces respectively along the X_u and Y_u . They are expressed in function of lateral tire contact forces, steering angle δ and articulation angle ψ_f .

III. ROBUST OBSERVERS DESIGN

To estimate lateral forces, we propose in this section to develop an observer based on the first order sliding mode approach followed by an estimator. This approach is robust versus the model and the parameters uncertainties for state estimation and is able to reject perturbations and uncertainties effects.

A. Model Parametrization

The obtained dynamics equations are written in state form in order to allow design of an observer based on the sliding mode approach [13]. The observer is used to reconstructs the global dynamics and then we can estimate the lateral tires forces. The choice of the sliding mode approach is motivated by its robustness with respect to the parameters and modeling

errors [17]. The state variables of the model expressed in the unsprung mass reference frame are as follows:

$$\dot{x} = f(x, \delta, F) \quad (6)$$

$$x = (\phi, \psi_f, v_x, v_y, \dot{\psi}, \dot{\phi}, \dot{\psi}_f) \quad (7)$$

with $\dot{\psi}, \dot{\phi}, \dot{\psi}_f$ to represent respectively the yaw, the roll and the rate of change of the articulation angle ψ_f . Here F represent the unknown input forces and the steering angle δ represent the known system input [17].

In our case, we assume available for measurements the roll angle ϕ , the angle between tractor and trailer (relative yaw at the fifth wheel) ψ_f , the yaw velocity $\dot{\psi}$ and the vehicle velocities v_x and v_y . The unknown variables are the state components $\dot{\phi}$ and $\dot{\psi}_f$, and lateral tire forces F . The state vector is then split in two parts $x^T = [x_1^T, x_2^T]^T$ with: $x_1 = (\phi, \psi_f)^T$ measured and $x_2 = (v_x, v_y, \dot{\psi}, \dot{\phi}, \dot{\psi}_f)^T$.

The system (6) can then be written

$$\begin{cases} \dot{x}_1 = \rho x_2 \\ \dot{x}_2 = f_1(x_1, x_2) + f_2(x_1, \delta, F) \\ y = x_1 \end{cases} \quad (8)$$

where $\rho = \begin{bmatrix} 0 & 0 & 0 & 1 & 0 \\ 0 & 0 & 0 & 0 & 1 \end{bmatrix}$, and f_1 et f_2 are analytic functions defined in \mathbb{R}^5 .

The function $f_1(x_1, x_2)$ may be parametrized as: $f_1(x_1, x_2) = \varphi(x_1, x_2, \delta) \cdot \theta_o + \zeta$ with θ_o a vector of nominal system parameters (θ_o the nominal values of the vector θ) and, $\varphi(x_1, x_2, \delta)$ a regression vector depending on well-known functions of (x_1, x_2, δ) . The remaining term ζ is a small and bounded perturbation representing modeling errors due to use of approximations. The function $f_2(x_1, \delta, F)$ may be written [2]:

$$f_2(x_1, \delta, F) = \Omega(x_1, \delta) F \quad (9)$$

$$f_1(x_1, x_2) = \varphi(x_1, x_2, \delta) \cdot \theta_o + \zeta \quad (10)$$

Ω is a matrix in $\mathbb{R}^{3 \times 5}$. The vector x_2 is composed of both measured variables v_x, v_y and $\dot{\psi}$, and unknown variables $\dot{\phi}, \dot{\psi}_f$. The vector $x_2 = (x_{21}, x_{22})^T$ is made of two components, the first part $x_{21} = (v_x, v_y, \dot{\psi})^T$ is measured and $x_{22} = (\dot{\phi}, \dot{\psi}_f)^T$ the unknown variables to be robustly observed.

The model may be rewritten in an explicit triangular form with Bounded Input and finite time Bounded State (BIBS) a follows[11]

$$\begin{cases} \dot{x}_1 = \rho x_2 = x_{22} \\ \dot{x}_2 = D \begin{pmatrix} x_{21} \\ x_{22} \end{pmatrix} + \Omega(x_1, \delta, F) \\ y = x_1 \end{cases} \quad (11)$$

The matrix D defined in $\mathbb{R}^{5 \times 5}$ depends on the state x and Ω is a matrix defined in $\mathbb{R}^{5 \times 3}$.

B. First Order Sliding Mode Observer

1) *The Backstepping Observer*: To estimate both forces and velocities, starting with as measurement x_1 and x_{21} ,

we propose the following sliding mode observer giving the estimates \hat{x}_1, \hat{x}_{22} in two steps[11][12]:

$$\begin{cases} \dot{\hat{x}}_1 = \hat{x}_{22} + \Lambda_1 \text{Sign}_1(x_1 - \hat{x}_1) \\ \dot{\hat{x}}_2 = D \begin{pmatrix} x_{21} \\ \bar{x}_{22} \end{pmatrix} + \Omega(x_1, \delta) \hat{F} + \eta \end{cases} \quad (12)$$

$$\eta = \begin{pmatrix} \Lambda_{21} & 0 \\ 0 & \Lambda_{22} \end{pmatrix} \begin{pmatrix} \text{Sign}_2(x_{21} - \hat{x}_{21}) \\ \text{Sign}_2(\bar{x}_{22} - \hat{x}_{22}) \end{pmatrix} \quad (13)$$

$\Lambda_1, \Lambda_{21}, \Lambda_{22}$ are observer gains to be adjusted for convergence, \hat{F} is an a priori estimation of the forces and Sign_i is the vector of sign functions for $t > t_1$. The auxiliary variable \bar{x}_{22} is introduced for the design of the backstepping triangular observer (see [11] for this observer):

$$\bar{x}_{22} = \hat{x}_{22} + \Lambda_1 \text{Sign}_{1,moy}(x_1 - \hat{x}_1) \quad (14)$$

2) *Finite time Convergence of the observer:* For the convergence analysis, we have to express the state estimation error ($\tilde{x}_i = \hat{x}_i - x_i$) dynamics equation. Owing to the system triangularity we can study its behavior step by step.

$$\begin{cases} \dot{\tilde{x}}_1 = \bar{x}_{22} - \Lambda_1 \text{Sign}_1(x_1 - \hat{x}_1) \\ \dot{\tilde{x}}_2 = \Delta + \Omega(x_1, \delta) \tilde{F} - \eta \end{cases} \quad (15)$$

$$\Delta = D \begin{pmatrix} x_{21} \\ x_{22} \end{pmatrix} - \hat{D} \begin{pmatrix} x_{21} \\ \bar{x}_{22} \end{pmatrix} \quad (16)$$

$$\tilde{F} = F - \hat{F} \quad (17)$$

Step 1: Finite time convergence of \hat{x}_1 to x_1 in t_1 seconds:

During this step the second sign function is chosen as null $\text{Sign}_2 \cong 0$ for $t < t_1$. The observation error dynamic (15) becomes:

$$\begin{cases} \dot{\tilde{x}}_1 = \bar{x}_{22} - \Lambda_1 \text{Sign}_1(x_1 - \hat{x}_1) \\ \begin{pmatrix} \dot{\tilde{x}}_{21} \\ \dot{\tilde{x}}_{22} \end{pmatrix} = \Delta + \Omega(x_1, \delta) \tilde{F} \end{cases} \quad (18)$$

Let us recall that the system is BIBS and consider the following Lyapunov candidate function and compute its derivative

$$V_1 = \frac{\tilde{x}_1^T \tilde{x}_1}{2} \quad (19)$$

$$\dot{V}_1 = \tilde{x}_1^T (\bar{x}_{22} - \Lambda_1 \text{Sign}_1(\tilde{x}_1)) \quad (20)$$

If we chose $\Lambda_1 = \text{diag}(\lambda_1, \lambda_2)$ such as $\lambda_i > \|\tilde{x}_{22}(i)\|_{\max}$ for any $i = 1, 2$, then $\dot{V}_1 < 0$ and consequently the observation error \tilde{x}_1 goes to zero in a finite time t_1 . After t_1 is reached we have $\dot{\tilde{x}}_1 = 0$. Then after the Fillipov solution [19], we obtain in the mean average $\bar{x}_{22}(i) = \lambda_i \text{Sign}_{eq}(\tilde{x}_1(i))$. Owing to that $\text{Sign}_{eq} \cong \text{Sign}_{moy}$ on the sliding surface ($\tilde{x}_1 = 0$), we deduce that $\bar{x}_{22}(i) = x_{22}(i)$ and then $\bar{x}_{22} = x_{22}$. Note that Sign_{moy} is the mean of Sign , this can be considered as a low pass filtering used to reduce the chattering effect in sliding modes of the first order.

Step 2 : In this step, we are interested by convergence of \bar{x}_{22} in a finite time t_2 . Thereafter the estimation of the unknown input tire forces F can be processed.

Let us first replace the vector Sign_2 by the usual sign functions ($t > t_1$)

$$\dot{\tilde{x}}_1 = 0 = \bar{x}_{22} - \Lambda_1 \text{Sign}_1(\tilde{x}_1)$$

$$\dot{\tilde{x}}_2 = \Delta + \Omega(x_1, \delta) \tilde{F} - \Lambda_2 \text{Sign}(\tilde{x}_2)$$

The second Lyapunov function considered is:

$$V_2 = \frac{\tilde{x}_1^T \tilde{x}_1}{2} + \frac{\tilde{x}_2^T \tilde{x}_2}{2} \quad (21)$$

$$\dot{V}_2 = \tilde{x}_2^T \dot{\tilde{x}}_2 \text{ for } t > t_1 \quad (22)$$

$$V_2 = \tilde{x}_2^T \left(\Delta + \Omega(x_1, \delta) \tilde{F} - \Lambda_2 \text{Sign}(\tilde{x}_2) \right) \quad (23)$$

Knowing that \tilde{F} is bounded and choosing $\lambda_2 = \text{diag}(\gamma_1 \dots \gamma_5)$ with γ_i large enough ($\gamma_i > |\Delta + \Omega(x_1, \delta)|_{\max}$), the convergence of \tilde{x}_2 to zero is guaranteed in a finite time $t_2 > t_1$ then we will have $\dot{\tilde{x}}_2 = 0$, consequently. Then we obtain:

$$\Delta + \Omega(x_1, \delta) \tilde{F} - \Lambda_2 \text{Sign}_{eq}(\tilde{x}_2) = 0 \quad (24)$$

3) *Unknown Input Estimation and Conclusion:* As $\bar{x}_{22} = x_{22}$, then as we have chosen $\hat{D} \approx D$ and then $\Delta \approx 0$.

Let us define $Q = \Omega^T \Omega$ and assume that it is invertible. The observation error dynamic is then reduced to:

$$\tilde{F} = Q^{-1} \Omega^T \Lambda_2 \text{Sign}_{eq}(\tilde{x}_2) = F - \hat{F} \quad (25)$$

Now, we can define a vector \bar{F} as being an estimation of forces. Furthermore, after the first and second step (for $t > t_2$) as we have $\bar{x}_2 = x_2$, the expression of this vector \bar{F} becomes:

$$\bar{F} = \hat{F} + Q^{-1} \Omega^T \Lambda_2 \text{Sign}_{moy}(\tilde{x}_2) \quad (26)$$

$$\bar{F} = \hat{F} + Q^{-1} \Omega^T \begin{pmatrix} \Lambda_{21} & 0 \\ 0 & \Lambda_{22} \end{pmatrix} \begin{pmatrix} \text{Sign}_{2,moy}(x_{21} - \hat{x}_{21}) \\ \text{Sign}_{2,moy}(\bar{x}_{22} - \hat{x}_{22}) \end{pmatrix}$$

After time reaches t_2 we have $\text{Sign}_{eq}(\cdot) \cong \text{Sign}_{moy}(\cdot)$, during this second step the signal $\bar{x}_2 = x_2$ is reached, assuming that conditions of the first step remain valid after t_1 , we can then conclude that for any $t > t_2$ we have $\bar{F} \simeq F$ in the mean average.

Then the observer proposed (equations (12) and (14)) with respect to depicted conditions and the gain matrices choices (Λ_1, Λ_2), gives a robust estimation of the global system state (the heavy vehicle dynamics in a cornering) converging in a finite time and the equation (26) gives reconstruction of the unknown input pneumatics tire lateral forces. We have used the robust first order sliding modes approach to estimate the system state in two steps. The robustness versus modeling errors and finite time convergence allow us to avoid knowledge of input in the first step and being able to retrieve them with a simple backstepped procedure.

C. Second Order Sliding Modes

1) *Second Order SM Observer*: In this subsection we propose an observer based on second-order sliding mode approach, to increase robustness versus parametric uncertainties, modelling errors and disturbances. We propose an observer following the same guidelines as in our previous work in [12][13][17] applying the approach of [18]. As in the previous observer \hat{x}_1 and \hat{x}_2 are the state estimations. Let z_1 and z_2 be vectors of observation adjustment given by the super-twisting algorithm defined as follows:

$$\begin{aligned} z_1 &= \begin{pmatrix} \lambda_1 |x_{11} - \hat{x}_{11}|^{1/2} \text{Sign}(x_{11} - \hat{x}_{11}) \\ \lambda_2 |x_{12} - \hat{x}_{12}|^{1/2} \text{Sign}(x_{12} - \hat{x}_{12}) \end{pmatrix} \quad (27) \\ z_2^T &= (0 \ 0 \ 0 \ Z_2) \quad \text{with} \\ Z_2 &= (\alpha_1 \text{Sign}(x_{11} - \hat{x}_{11}) \quad \alpha_2 \text{Sign}(x_{12} - \hat{x}_{12})) \end{aligned}$$

Let us know chose as observer equation the following one where the first function ($f_1(x_1, x_2) = \varphi(x_1, x_2, \delta) \theta_o + \zeta$) is omitted like a bounded perturbation (recall that the system is BIBS) in order to be retrieved and estimated later.

$$\begin{cases} \dot{\hat{x}}_1 = \rho \hat{x}_{22} + z_1 \\ \dot{\hat{x}}_2 = f_2(x_1, \delta, \hat{F}) + z_2 = \Omega(x_1, \delta) \hat{F} + z_2 \end{cases} \quad (28)$$

\hat{F} may be any a priori estimation of the forces (eg we can consider it as proportional to the steering angle).

2) *Convergence of the Second Order Observer*: The observation error dynamics is then

$$\begin{cases} \dot{\tilde{x}}_1 = \rho \tilde{x}_{22} - z_1 \\ \dot{\tilde{x}}_2 = f_1(x_1, x_2) + \Omega(x_1, \delta) \tilde{F} - z_2 \end{cases} \quad (29)$$

As the system (11 or 8) has an explicit triangular form with Bounded Input and Bounded State (BIBS in finite time) and assuming that saturation is used for the estimated force signals used by the observer, we can easily see that there exist positive constants f_j^+ for $j = 1, \dots, 5$ such that $|f_1(x_1, x_2) + \Omega(x_1, \delta) \tilde{F}| \leq f_j^+$. Then we can find α_i and λ_i satisfying the inequalities:

$$\begin{aligned} \alpha_1 &> f_4^+ \\ \alpha_2 &> f_5^+ \\ \lambda_1 &> \sqrt{\frac{2}{\alpha_1 - f_4^+} \frac{(\alpha_1 + f_4^+)(1 + q_1)}{(1 - q_1)}} \\ \lambda_2 &> \sqrt{\frac{2}{\alpha_2 - f_5^+} \frac{(\alpha_2 + f_5^+)(1 + q_2)}{(1 - q_2)}} \end{aligned} \quad (30)$$

where $i = 1, 2$ and q_i is some chosen constant, $0 < q_i < 1$, [?].

The observer (28),(27) for the system (11) ensures then a finite time converging states estimations.

3) *Unknown Input forces estimation*: In order to reconstruct the unknown lateral forces from the available measures and the robustly observed state we develop an estimator in this subsection. The convergence of \hat{x}_2 in a finite time involves the equalities (which holds in mean average or low pass filtered version):

$$\dot{\tilde{x}}_2 = f_1(x_1, x_2) + \Omega(x_1, \delta) \tilde{F} - z_2 = 0 \quad (31)$$

$$z_2 = f_1(x_1, x_2) + \Omega(x_1, \delta) \tilde{F} \quad (32)$$

By its definition (27) the term z_2 changes a very high frequency (theoretically infinite). Let us consider a low pass filtered version of this signal \bar{Z}_2 .

$$\begin{aligned} \bar{Z}_2 &= \overline{\alpha \text{sign}(\tilde{x}_1)} = f_1(x_1, x_2) + \Omega(x_1, \delta) \tilde{F} \\ &= \varphi(x_1, x_2, \delta) \theta_o + \zeta + \Omega(x_1, \delta) \tilde{F} \end{aligned}$$

θ_o is a known vector of nominal parameters, $\varphi(x_1, x_2, \delta)$ is a vector of known functions of measurements or state components and ζ is a perturbation term which is rendered as small as possible by the choice of the apriori estimation θ_o .

We can then retrieve s the signal which will allow us to estimate the unknown input forces F .

$$\begin{aligned} s &= \bar{Z}_2 - \theta_o \varphi(x_1, x_2, \delta) = \Omega(x_1, \delta) \tilde{F} + \zeta \\ \Omega^T s &= \Omega(x_1, \delta)^T \Omega(x_1, \delta) \tilde{F} + \Omega^T \zeta \\ \Omega^T s &= Q \tilde{F} + \Omega^T \zeta \\ \tilde{F} &= F - \hat{F} = Q^{-1} \Omega^T s - Q^{-1} \Omega^T \zeta \end{aligned}$$

As $Q = \Omega^T \Omega$ is invertible, the input force expression can be retrieved and we can write :

$$F = \hat{F} + Q^{-1} \Omega^T [\bar{Z}_2 - \theta_o \varphi(x_1, x_2, \delta)] - Q^{-1} \Omega^T \zeta \quad (33)$$

Since after in finite time we have an estimation of the forces $\tilde{F} = \hat{F} + Q^{-1} \Omega^T [\bar{Z}_2 - \theta_o \varphi(x_1, x_2, \delta)]$.

IV. SIMULATION RESULTS

In this section, we give some results in order to test and validate our approach an the proposed observers. In simulation, the forces are generated by use of the Magic Formula tire model [9]. The input (Steering angle) of model applied is shown in (4).

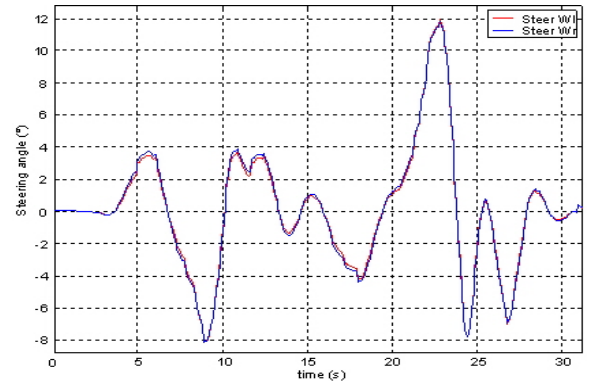
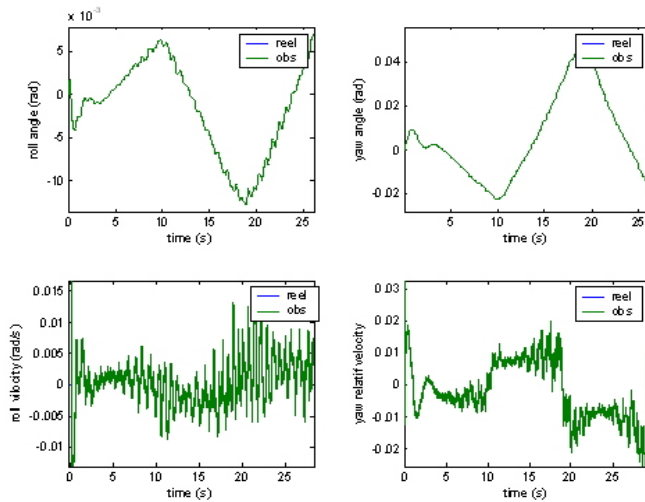

Fig. 4. Steering angle

The corresponding constant are :

Observer Parameters : $\alpha_1 = 1.00$, $\alpha_2 = 1.02$, $\lambda_1 = 2.6104$, and $\lambda_2 = 2.6103$. So, the performance of the observer for sampling interval $\delta = 0.00001$ is shown in observation results.

The (figure) and (figure) shown the convergence of the estimated state vectors to their actual value in finite time. In (figure) we show the asymptotic convergence of the tire force to actual values.



The performance of this estimation approach is satisfactory since the estimation error is minimal for state variables. So, the unknown parameters converge to their actual values.

V. CONCLUSIONS

In this paper, we have presented a new observation and estimation approach suitable for heavy vehicle. We estimate the lateral forces using observer based first and second-order sliding mode algorithm. The finite time convergence of the observer is useful for robustness of the forces retrieval. Simulation results are presented to illustrate the ability of this approach to give estimation of both vehicle dynamics states and lateral tire forces. The robustness of the twisting algorithm versus uncertainties on the model parameters has also been emphasized in simulation.

REFERENCES

- [1] H Desfontaines. CEESAR : "Centre Européen d'Etudes de Sécurité et d'Analyse des Risques". RVI Internal report, January 2005, RENAULT TRUCKS - Advanced Engineering Lyon and Report L1a, Thème 11; ARCOS 2004.
- [2] N.K. M'Sirdi et al. Elaboration d'alertes pour les poids lourds en situations accidentogènes. Contrôlabilité et les critères de stabilité. Rapport L2, Thème 11; ARCOS 2004. <http://www.arcos2004.com/>
- [3] N.K. M'Sirdi et al. Elaboration d'alertes pour les poids lourds en situations accidentogènes. Observateur par mode de glissement, Reconstruction de l'état dynamique d'un véhicule lourd. Rapport L3, Thème 11; ARCOS 2004. <http://www.arcos2004.com/>
- [4] E. Dahlberg. Commercial vehicle stability – Focusing on rollover. Ph.D. thesis, Royal Institute of Technologie, 2001.
- [5] R. Ervin, C. Winkler, P. Fancher, M. Hagan, V. Krishnaswami, H. Zhang, S. Bogard. Two active systems for enhancing dynamic stability in heavy truck operations. technical report, UMTRI-98-39, 1998.
- [6] P. J. Liu, S. Rakheja, A.K.W. Ahmed. Detection of dynamic roll instability of heavy vehicles for open-loop rollover control. in SAE paper 973263, 1997.
- [7] S. Rakheja, A. Piché. Developpement of directional stability criteria for an early warning safety device. in SAE paper 902265, 1990.
- [8] C.Chen, M. Tomizuka. modelling and control of articulated vehicles. technical report, UCB-ITS-PRR-97-42, University of California, Berkeley, 1997.

- [9] H. Pacejka and Besselink. Magic formula tire with transient properties. *Vehicle System Dynamics*, vol 27, pp 234-249, 1997.
- [10] J. Ackermann. Active steering for better safety, handing and comfort. In *advances in Vehicle control and Safety*, Amiens, France, 1998.
- [11] N.K. M'Sirdi, N. Manamanni et D. El Ghanami. Control approach for legged robots with fast gaits: Controlled Limit Cycles. *Journal of In-telligent and Robotic Systems*, 27 (Issue 4): pp 321-343, April 2000. Kluwer Academic Publishers.
- [12] N.K. M'sirdi, A. Rabhi, N. Zbiri and Y. Delanne. VRIM: Vehicle Road Interaction Modelling for Estimation of Contact Forces. TMVDA 04. 3rd Int. Tyre Colloquium Tyre Models For Vehicle Dynamics Analysis August 30-31, 2004 University of Technology Vienna, Austria.
- [13] N.K. M'sirdi, A. Rabhi, L. Fridman, J. Davila and Y. Delanne. Second Order Sliding-Mode Observer for Estimation of Vehicle Parameters. Submitted to IEEE TCST, octobre 2005. IEEE Transactions on Control Systems Technology.
- [14] V. Utkin, J. Guldner, J. Shi. *Sliding Mode Control in Electromechanical Systems*. London, UK: Taylor & Francis; 1999.
- [15] V. I. Utkin. *Sliding mode and their application in variable structure systems*. Mir, 1977.
- [16] J. J. E. Slotine, J. K. Hedrick, E. A. Misawa. Non linear state estimation using sliding observers. in *IEEE Conf. on Deision and control*, p.332-339, Athen, Greece, 1986.
- [17] N.K. M'Sirdi, A. Rabhi, L. Fridman, J. Davila and Yves Delanne Second Order Sliding-Mode Observer for Estimation of Vehicle Parameters , Accepted in ACC2006: American Control Conference, Minneapolis, Minnesota USA .
- [18] J. Davila and L. Fridman. Observation and Identification of Mechanical Systems via Second Order Sliding Mode. in *Proceedings of the 8th International Workshop on Variable Structure Systems (VSS'04)*, September 6-8, 2004, Vilanova la Geltru, Spain..
- [19] A. F. Filippov. Differential equations with discontinuous right hand side. *American Mathematical Society transactions*, Vol. 62, pp. 199-231, 1960