

The systemic approach in technology education: Effects of transferred learning in physical science problem solving

Colette Andreucci -Marjolaine, Marjolaine Chatoney, Jacques Ginestié

► **To cite this version:**

Colette Andreucci -Marjolaine, Marjolaine Chatoney, Jacques Ginestié. The systemic approach in technology education: Effects of transferred learning in physical science problem solving. *International Journal of Technology and Design Education*, Springer Verlag, 2010, 22, pp.281-296. 10.1007/s10798-010-9148-y . hal-02473517

HAL Id: hal-02473517

<https://hal-amu.archives-ouvertes.fr/hal-02473517>

Submitted on 10 Feb 2020

HAL is a multi-disciplinary open access archive for the deposit and dissemination of scientific research documents, whether they are published or not. The documents may come from teaching and research institutions in France or abroad, or from public or private research centers.

L'archive ouverte pluridisciplinaire **HAL**, est destinée au dépôt et à la diffusion de documents scientifiques de niveau recherche, publiés ou non, émanant des établissements d'enseignement et de recherche français ou étrangers, des laboratoires publics ou privés.

The systemic approach in technology education: Effects of transferred learning in physical science problem solving

Colette Andreucci - Marjolaine Chatoney - Jacques Ginestié

UMR P3 ADEF, Aix-Marseille Université - INRP.

Abstract

The purpose of this study is to verify whether pupils (15-16 years old) who have received technology education on a systemic approach of industrial systems, are better than other pupils (of the same age but from other academic domains such as literary ones or ones that are economics-based ...) at solving physical science problems which involve systemic reasoning.

The results show that there is a positive transfer effect of the systems approach applied to industrial automatisms on systems of another nature (hydrodynamic and electrical problems). However this effect is less important for the pupils who study engineering sciences initiation for just one year (ISI) than for those who continue this education (SI) for a further year.

Key words: Systemic thinking, technological education, transfer of learning, technical systems.

Introduction

Technology education as a subject in general education in France is compulsory for all pupils from 3 to 15 years old. After that, technology education becomes optional until the 'bachelor' examination (17-18 years old). From 15 to 18 years old, technology education is taught in the course 'Introduction to Engineering Sciences' (ISI) option for 15-16 year olds and in the "Engineering Sciences" (SI) option for 16-18 year olds. Not all pupils choose technology. They can choose other options such as: art, foreign and classic languages, economic and social sciences, management information and communication, physics-chemistry laboratory, physical education and sports activities. The choice of these options depends largely on the type of *baccalaureate* aimed for at the end of year 13. For example: arts and languages options are preferred for the "literary" baccalaureate, design options are preferred for the "art" baccalaureate. For pupils wishing to study for an "Industrial Science and Technology" (STI) baccalaureate, there are two recommended options: computer and production systems and Introduction to Engineering Sciences. This last option (ISI) is also recommended for pupils who intend to pursue a scientific bachelor course in addition to the physics measurements and technology of information option. This article is focused on ISI and SI options. These two technical courses replaced the former option called "Automated Systems Technology" (TSA) which was introduced in 1986. But there is very little change in the teaching content itself. The study of multi-technical systems is central to it. As the curriculum clearly indicates (BOEN, 2001), the systems approach, which forms the teaching basis, is clearly confirmed as an important part of the curriculum of the ISI option.

In general terms, it can be said that the concept of a system is defined as a dynamic and complex whole interacting as a structured functional unit and a set of interlinked elements, in which the whole is greater than the sum of its parts. Generally speaking, the general systems theory (Von Bertalanffy, 1968) is a search paradigm in opposition with the analytical nature of the Cartesian model. Thus this paradigm allows one to rethink phenomena in the majority of domains such as biological and natural (de Rosnay, 1975), social (Morin, 1990), artificial (Lemoigne, 1990; Simon, 1991) or cognitive (Inhelder & Cellierier, 1992). In a technology education context, the central concept of a system also constitutes an important change which probably has an effect upon the pupils' ability to tackle problems in a more holistic and structured way.

The need to consider technical artefacts as systems rather than simple objects, that can be taken apart and which are without any clear boundaries was stated very early (Gilles, 1978; Deforge, 1985). The systems approach also led to a new way of designing technological education (Barak, 1990, 2007; Brown et al, 1989; Dubois & Gatiser, 2005; Dorst, 2006; de Vries, 2005). From this perspective, the curriculum of the ISI option explicitly implicates several components of the systemic approach: functional, structural and behavioural, allowing one to determine how a system should be perceived and used. Among other characteristics, this teaching structure is presumed to be coherent with current engineering practices used in industry.

The curriculum of ISI also clearly emphasises the cognitive benefits of this systemic approach to industrial systems: "The functional approach develops analysis qualities. The structural approach calls upon technical skills and plays a part in summarising the design activity. The behavioural approach highlights the effects,

notably the physical sciences and the processes involved in making a system function. This leads the pupils to think about the validity of results obtained with the help of models" (BOEN, 2001).

Therefore, we can expect that pupils who only learn ISI (15-16 years old) or who learn ISI (15-16 years old) + SI (16-17 years old) are more able than other pupils to solve all sorts of systems-based thinking problems (technical, biological, physical sciences ...).

Following previous studies on the TSA option (Ginestié, 1992), this study examines whether such effects exist. It is more specifically concerned with theoretical models and practical investigations carried out in France in technology education (Andreucci, 2006, 2008; Chatoney, 2005, 2006; Ginestié, 2008; Froment, 2002; Lebahar, 2006 ; Lebeaume, 2000; Martinand, 2003). More precisely, this research is an extension of the study on natural thinking processes in hydrodynamics (Blondin, Closset & Lafontaine, 1992) which showed the difficulties that students encounter in applying systems thinking. Thus, to verify our hypothesis, we have duplicated the task previously studied by these authors.

In keeping with lots of french education research preoccupied with looking at the types of reasoning used by pupils in different areas of physical sciences (Closset, 1989; Joshua & Dupin, 1993; Tiberghien, 2003; Viennot, 2006) Blondin, Closset & Lafontaine (1990, 1992) these studies have themselves highlighted, with regard to hydraulic circuits, the use by 'novice' pupils of ways of natural, local, sequential and constant flow reasoning similar to those described for electric circuits.

Method

Data collection

Pupils have to solve two problems during a written exam. The first one (P1) (figure 1) is the same as the questioning (diagram and statement) used by Blondin et al. (1992).

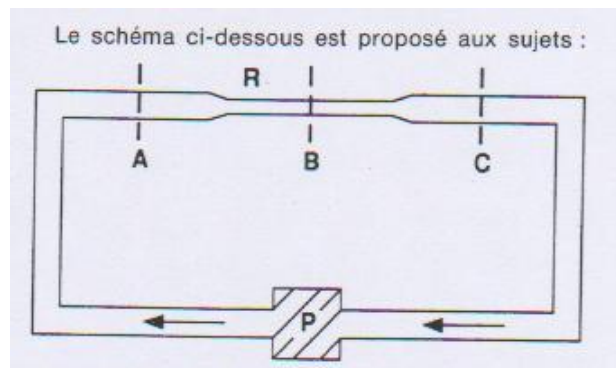

Figure 1: Hydraulic circuit (P1)

It deals with a horizontal hydraulic circuit in which the fluid circulates using a pump P going from point A to B, and then to point C. Firstly (Situation 1: S1), two multiple choice questions invite pupils to compare the flow (defined by "the quantity of water that flows per second") between points A and B, then to compare the flow between points B and C, taking into account that a narrowing of the pipe occurs at point B situated between A and C. Secondly (situation 2: S2), pupils are told that the diameter of the pipe has been reduced to a greater extent at point B. Here in S2, they have to appreciate the flow at each point (A, B, C) in comparison to what it was in S1.

The second problem (P2) applies the same questioning about an electrical circuit including a current generator and a resistor R (Figure 2).

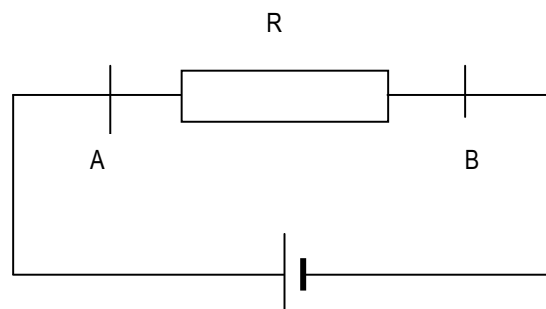

Figure 2: Electric circuit (P2)

Firstly, pupils have to compare electrical intensity (defined by “the quantity of electrons per second”) upstream (point A) and downstream (point B) of the resistor. Then pupils have to say whether the electrical intensity changes at each point (A, B) after an increase of the resistor (between A and B). This problem is logically similar to the previous one and holds the same interests as the first one.

Indeed, in these two problems, no calculation is necessary. The questions focus only on comparing flow values in different parts of the series circuit and the influence of increasing the pressure drop. These flows are equal according to the principle of continuity in the case of incompressible fluid: there is no possibility of accumulation. All the examples of continuity equations express the same idea: a conserved quantity cannot increase or decrease, it can only move from place to place.

So, both problems can be solved without specific knowledge of physical science: a systemic view based on the “conservation principle” of fluid within a closed circuit, is sufficient to answer correctly. Consequently, another point of interest is that this kind of problem can be solved by non-scientific pupils. Furthermore, the point of having a second problem (electrical circuit) is to confirm whether or not the content has an effect on pupils answers.

Sample

As we mentioned previously, technology education is taught in the 'Introduction to Engineering Sciences' (ISI) option in year 11 (15-16 years old, first year of upper secondary school) and in the "Engineering Sciences" (SI) option for 16-18 year olds (year 12 and year 13). The table below shows the repartition of the sample studied.

Age Level	16-17 Year 12		17-18 Year 13	
With ISI in Year 11	58	37 Scientific (S) (* included 7 with SI)	31	7 Scientific (S) (* included 4 with SI)
		18 Sciences and Industrial Technology (STI)		20 Sciences and Industrial Technology (STI)
		3 Economical and Social Sciences (ESS)		4 Biological Sciences
Without ISI in Year 11	16	16 Economical and Social Sciences (ESS)	10	10 Scientific (S)
Total subjects		74		41

Table 1: Repartition of students' sample in the various sections

We collected answers from 74 pupils in year 12 and answers from 41 pupils in year 13. Among students of year 12, 58 people previously studied (in year 11) the ISI option and 16 pupils took another option (Economical and Social Science). Among the 58 ex ISI students, 37 subjects are now in the scientific section (S), 18 are in a technological section (STI) and 3 subjects are in the Economical and Social Sciences section (ESS). The 16 pupils in year 12 who don't study ISI are now in the economical and social section (ESS). Among the 41 pupils in year 13, 31 studied ISI in year 11: 7 of them are now in the scientific section (S), 20 of them are in a technological section (STI) and 4 of them in a biological science section. The 10 pupils who do not study ISI in year 11 are in a scientific section.

Among the ex ISI students we can also differentiate those who kept the course “engineering sciences” and those who left it and are then less familiar with a systemic approach of industrial processes.

In year 12, among the 37 students in the scientific section, only 7 students stay in the SI option. In year 13, only 4 out of 7 students continue with SI. Hence, these pupils should be the ones who perform better if the ability to think logically about technical systems reinforces science skills expectedly acquired in the field of systemic reasoning. All pupils from this sample come from the same school.

Categorising answers

We know (Blondin et al, 1992) that novices who have not received specific training in the field of hydrodynamics usually believe that the flow is weaker in the narrow part of the pipe (B) than upstream (A) and downstream (C) (cf. type 2 answers, table 2). This perception corresponds to a type of natural reasoning called “local” view: in a closed circuit, local reasoning will consider that actions or changes occurring in the

circuit will produce an effect localised exclusively where the action takes place. Other arguments of local type (cf type 5 answers, table 2) assume that the flow is greater in B than upstream (A) and that it becomes weaker downstream (C). We know that novices can also think that the pipe narrowing is accompanied (in B) by a reduced flow, or by a greater flow which retains this reduced or increased value in point C (cf. type 3 and type 6 answers, table 2). These types of responses are characteristic of a "sequential" view also identified in the electricity domain (Closset, 1989). This reasoning follows the flow (or current in the event of an electrical circuit) from the source (pump or battery) and will consider that various obstacles (narrowing, resistance) have no impact upstream from where they take place. On the contrary, systems thinking (type 1 answers) are focused on a cyclical process rather than linear cause and effect. Therefore, we expect that pupils who studied technological systems during one year (ISI in year 11 classes) or several years (ISI + SI in year 12 and year 13 classes) are able to transfer a systemic view on P1 and P2.

Results Analysis

Thoughts on the hydrodynamic problem (P1)

The flow at different points in a series circuit (S1)

Table 2 presents the data for the first situation, S1. The different types of answers are recorded, as previously described and the table indicates for each pattern of responses the percentages of students who gave these responses.

First level. Firstly, it may be useful to compare pupils whose thinking relates to constant flow (type 1 answers) with those who adopt a local point of view, according to Blondin et al. that "*considering the fact that actions or modifications carried out upon the circuit (closing a valve or increasing resistance, for example) only have a local effect, at the point where these actions take place*".

Types of Answers	Answers relating to flow at A, B, and C	Year 12		Year 13	
		with ISI	without ISI	with ISI	without ISI
1	A = B = C	35	6	26	40
2	A > B < C	17	56	16	20
3	A > B = C	24	12	16	20
4	A > B > C	7	0	13	0
5	A < B > C	17	26	19	0
6	A < B = C	0	0	7	0
7	A < B < C	0	0	3	20
Total of answers		100%	100%	100%	100%
N Pupils		58	16	31	10

Table 2: Data distribution (% of students) according to each pattern of responses observed on flow comparison at points A, B and C (Nota: correct pattern of answers is in bold).

According to this simple dichotomic categorisation, we notice a clear difference in year 12 where 35% of ex ISI pupils opt for a constant/continual flow versus 6% of pupils who studied the economical and social option (ESS). A more detailed analysis shows also that 2 on 3 ex ISI students in ESS give good answers. On the other hand, pupils from scientific year 13 classes have better control over the situation than their friends who studied ISI (40% of type 1 answers compared to 26%). Knowing that it appears relatively easy to generate relevant points of view using a teaching of the principles of hydrodynamics (cf. the results obtained by Blondin et al. from an experimental group), this may explain the better performance of year 13 scientific (S) pupils whose knowledge of physical sciences is more extensive. Indeed the principles involved (conservative flux and conservation law) are true in many scientific fields. Thus, for these scientific pupils, the learning transfer is easier than for other pupils because it concerns the same area of knowledge. On the contrary, for ex ISI students, most of who are now in a technology section, it would constitute a trans-disciplinary transfer. If we add all local points of view, this first categorisation would tend to indicate an influence of ISI on a regression in this kind of thinking. Nevertheless, this influence seems to only appear for a certain amount of time. Indeed, we notice a small decrease in the performance of ex ISI pupils between year 12 and year 13: judgments in favour of a constant flow regress from one year to the next (from 35% to 26%).

This positive influence of the technology option seems to be confirmed by taking into account two secondary variables: first, the marks obtained by students throughout year 11 and collected separately; secondly whether the students continue the SI option afterwards. The majority of points of view in favour of constant

flow were given by students whose marks in ISI were good or very good (75 % of type 1 answers compared with 25% for those whose performances were just average). The moderate importance of this result remains positive, because of various uncontrolled factors related to educational research in situ. With natural groups, it is always difficult to be sure that the observed differences can be related to the macro-variable studied.

Moreover, we notice a massive difference between the points of view expressed by pupils from SI, and those who dropped the technology option after year 11. Indeed, a further analysis of the data shows that ex ISI pupils who continued with sciences and industrial technology gave 63% of correct answers (type 1) versus 23% for those who did not carry on with the SI option (KHI^2 sign. 009).

Hence, ISI would only provisionally help to change manners of thinking which are usually dominant among novices. The usual way of reasoning will subsequently prevail, showing that it is not an acquisition that is really consolidated at the end of year 11. This consolidation would become much evident for pupils who continue to study engineering systems in year 12.

Second level. Secondly, it seems important to consider all types of local points of view. Indeed, to oppose local reasoning with constant reasoning is simply equivalent to opposing correct and incorrect answers. That doesn't take into account the diversity of incorrect answers and their underlying explanations. Here again, data can be examined in different ways. Several groupings can be made:

a) Firstly, we can compare those who believe that the narrowing induces a reduced flow (type 2,3 and 4) with those who think the opposite – that the flow is more important in B (responses 5, 6, 7). The first opinion is largely dominant. It appears mainly linked to two types of ideas:

- The flow is estimated to be smaller at point B *“with the smaller diameter, the water has less room to move”, “its volume is reduced as a result of the smaller pipe capacity”*;
- The flow is described as being *“slowed down”* or *“slower”* due to the fact that *“the water is slowed down as a result of the pipe narrowing”*.

Hence, we can see that the majority of pupils refer either to a spatial parameter (diameter, volume, even the “capacity” of the pipe to reduce the volume of water that flows through) or to a temporal variable (speed of circulation), which comes into play with the notion of flow, without making the link between the two factors.

In contrast, pupils who believe that the flow value is higher where the pipe is narrowed (point B) don't refer to volume or speed, but to pressure. For them, there is no distinction between notions of pressure and flow: *“the flow is stronger because the smaller the passageway, the more pressure there is”*. Consequently, the types of local point of view seem to be linked to different notions which are not associated, which leads pupils to focus on only one of them.

b) Another way of examining the data is to group together the answers given by those who believe that the change in the flow at point B is replicated at point C (responses of type 3 and 6) in order to compare them – on the one hand with the answers given by pupils who consider that the flow at point B is either weaker or stronger than the flow in A and in C (response types 2 and 5) – and on the other hand, with answers given by those whose points of view seem uncertain, because the flow at the narrowed point is estimated sometimes smaller and sometimes greater than upstream or downstream (type 4) or the opposite (type 7)

c) After having emphasised the fact that type 2 answers, which are dominant among novices (like for year 12 non ISI pupils) are representative of a local focus kind of reasoning, we could also, as Blondin et al. do, bring type 2 and 3 answers together, given that : *“Both these types of answer are typical of a sequential reasoning, already well-known in the electricity domain : this way of thinking involves following the flow (or the current in the case of electric circuits) starting with the voltage source (pump or battery) and acknowledging that the different obstacles (narrowing, resistance) in the current's path have no impact further up from the place where they are found “*.

Nevertheless, according to the justifications given by our pupils, we cannot assimilate type 2 and type 3 responses. Indeed, type 3 answers are often accompanied by a new argument, stating that *“what passes through B also has to pass through C”*. On the other hand, type 2 answers are mainly focused on the idea that the flow depends exclusively upon the diameter of the pipe at each point. In other words, pupils giving type 3 answers (or type 6) finally express judgments in line with the constant flow in some cases (downstream from the modification). So, if we can draw a parallel with piagetian tests for the conservation of physical quantities, we would deal with *“intermediary subjects versus those that are said to be “conservants”¹ (answers of “regular” flow²) or “non-conservants (absolutely local points of view).*

Third level. Thirdly, it is necessary to analyse to what extent pupils differ from each other in terms of reasoning. It would appear useful to reserve the notion of local focus reasoning (or “level 1”) for thinking about a modification having a strictly localised effect at the place where it occurs in the circuit (answers type 2 + 4 + 5 + 7). It is also necessary to affect the notion of sequential reasoning (or “level 2”) which involves

¹ It is somewhat surprising that a counter argument (like less water passes through B but it circulates faster, so the flow stays the same) which normally marks the passing from the intermediary stage to the conserving stage is never used here.

² This term seems preferable to that of “constant” flow, which may be deemed ambiguous, and which is reserved for qualifying the responses of pupils who esteem that the flow remains unchanged at all points in the circuit after an increased loss of charge. But one could also talk about “conservative flux “ as physicists do, or less technically, of “conservation of water quantity”.

thinking about the fact that this effect is propagated downstream without being reproduced upstream (answers type 3 + 6). Type 1 responses would be thus the only ones representing reasoning constant flux. According to this hierarchy, it seems that overall, the % of year 12 and year 13 pupils is the same within the three levels (28% and 29% respectively give level 1 answers; 22% and 22% provide level 2 answers; and 50% and 49% level 3 answers). If we contrast those having studied ISI with those not having taken the option, we see another insignificant difference ($KHI^2 = 3,36$) even though a trend seems to appear (32% of level 3 responses compared to 19% for “non ISI”; and 45% of level 1 responses versus 65% for “non-ISI”). These variables must be combined in order to see a significant difference ($KHI^2 = 8, 29$ sign.01) in year 12 classes whereas the option is shown to have no effect upon year 13 classes. For pupils in year 12 who studied ISI, we observe, however, a clear decrease in local reasoning (41% versus 81% for non ISI) with more reasoning of a sequential nature (24% versus 12% for non ISI) and mostly in favour of regular flow (35% versus 6% for non ISI).

This regression, however, is greater for pupils who studied the SI option in year 12: 11% of local points of view versus 89% for students who did not study ISI, or abandoned it at the end of year 11. Furthermore, we once again see a contrast (KHI^2 corrected sign.06) in year 13, with zero level 1 answers, but 75% level 3 answers for those who continued SI (compared to 54% and 24% respectively for those not having studied the option). The problem here is that we are still dealing with a much reduced group of pupils (4 in year 13 involved) due to the fact that in this particular secondary school, very few pupils decide to continue this option. This lack of year 13 pupils studying the SI option therefore explains that two years later there is no longer a difference between pupils having done ISI and those who have not. The positive impact of ISI is only short-term, unless its effect is consolidated by a prolonging of this teaching beyond the sixth grade.

Flow at different points in a series circuit, after an increase in loss of current (S2)

Participants were asked to compare for each point A, B and C, the flow as it was in S1, before an increase in the narrowing. As the authors discussing the problem point out, “*in a series circuit, the flow is inversely proportional to losses of current, mainly due to obstacles and narrowing, with all other things remaining the same*”. Hence, the flow decreases at the three locations³.

Types of answers	Comparison with the flow measured at the same place before increasing the pipe narrowing			Year 12		Year 13	
				Point A	Point B	Point C	with ISI
	1	-	-	-	18	0	23
2	=	=	=	23	6	14	40
3	=	-	-	13	26	27	20
4	=	-	=	9	13	3	10
5	=	+	+	2	6	3	10
6	=	+	=	14	6	14	10
7	=	=	+	2	6	0	0
8	+	-	-	7	13	3	0
9	+	-	=	4	6	0	0
10	+	-	+	2	6	3	10
11	-	-	+	0	6	0	0
12	-	=	=	2	0	10	0
13	-	+	+	4	6	10	0
Total				100%	100%	100%	100%
N Pupils				58	16	31	10

Table 3. Data distribution (%) of response types on the comparison of flows at each point before and after increasing the narrowing. (Nota: “- ; =; +” respectively means that the flow is considered inferior, equal or higher than it was before the increase in contraction)

³ (cf. the 1 answers in table 2 where – it means that the flow was judged as being lesser + greater, and = identical to what it was in S1).

The positive influence of ISI is confirmed here, since we notice that correct answers (in bold in the table) come exclusively from pupils who studied the option. It seems that, in itself, ISI instruction is helping to destabilize the usual spontaneous conceptions in promoting systemic type of reasoning. Because answers in favour of a generalised flow reduction can remain underpinned by a sequential approach, only taking into account the arguments which justify these judgments can allow us to be sure of their truly holistic nature. The verification of this point does not contradict the previous interpretation. It also reveals that the majority of pupils who give type 1 answers talk here about the "circuit" (*"the water finds it more difficult to circulate in the circuit, so the volume of water cannot be the same in the same amount of time"*, *"the circuit holds more resistance over the water"*, *"with the flow in B having lessened, it leads to a decrease at C and therefore at A"*). In contrast, the other types of answers never used this argument.

Previous ISI pupils currently in year 12 are also fewer (38% compared to half the pupils in the other groups) in answering that the flow is unchanged in A, but changed in B (responses 3 to 6). Contrary to the opinion that usually dominates (more than 25% pupils, for Blondin & al. or like here for "non ISI" pupils in year 12 or for previous ISI pupils in year 13), these subjects are also singular because fewer of them think that the flow stays the same at A but decreases at B and at C. The main argument from pupils who hold this point of view, is that *"nothing changes at A since the reduction is found afterwards, leading to a flow decrease at B where the water finds it more difficult to circulate then a decrease at C, because what flows at B has to flow at C"*. Most of the arguments given confirm the generally sequential nature of these responses. In these pupils' minds, the change made to the circuit cannot have any repercussion flowing upstream. Any influence can only be strictly local (responses 4 and 6 of this type *"at A and at C, the pipe stays the same, so the flow doesn't change"*) or possibly output effects (responses 3 and 5).

This sequential reasoning is also evident in the answers given by those who think, on the contrary, that the flow at B is greater than it was previously (answers 5 and 6). These points of view are supported by two kinds of ideas : 1) water flow is as fast as the pipe is narrow (*"the same amount of water flows in less space, so it circulates more quickly and the flow is higher"*); 2) that the pressure is as strong as the pipe is thin (*"as the narrowing is smaller, the pressure is greater and the flow is faster"*, *"the pressure increases thanks to the narrowing, so the flow is greater"*). Hence, these ideas are partially true, except that in one instance the pupils confuse flow and speed, and flow and pressure in the other. As pointed out by Blondin & al., we find the same wide range of answers with regard to the flow downstream from A as for the previous questions, some of which *"indicate a use of notions such as pressure or speed that induce errors"*

Some subjects affirm that the flow upstream from the pipe narrowing is greater than before (responses 8, 9, 10). These judgments are twice as common among year 12 students who have not done ISI (25%) as in the other groups. Associated with this kind of response we find, as was the case with previous research, the view of an increased flow which is linked to an *"accumulation phenomenon"* (*"Because it will be more difficult for the water to get into the tight narrowing, therefore the water will stagnate a bit more at point A"*). An analogy seems to exist between these points of view and circulation of road traffic when a road is narrowed.

We also notice that the dominant opinion (response 2) among year 12 ex ISI (23%), as in scientific year 13 (40%), corresponds to the natural way of thinking called *"constant flow reasoning"*, which *"consists of thinking about the fact that each circuit is characterised by a flow (or current) value, regardless of the possible modifications to other parameters (differences in pressure or potential, "resistances",...)"*.

With ex ISI pupils, we find also that 50% of those having taken the SI option give this kind of answer compared to only 12% for the others.

Closset (1989) interprets this constant current thinking as *"the ultimate adaptation in causal linear reasoning, for people who no longer fall into the traps of sequential reasoning, but who do not however take the whole system into account"*. According to our previous idea, we are probably dealing with answers of an intermediary level. Indeed, they show both a progression from strictly 'local' points of view, and represent a compulsory stage before the definitive access to a systemic way of thinking. Thus, the completed technology courses should have two kinds of positive effect: it allows some pupils to transfer a systems thinking into new situations; and to question the naive approach which involves analysing all systems step by step without consideration of their holistic aspect.

The impact of ISI appears more clearly if we take into account the intra-individual reactions to both situations. As Blondin & al. have already observed, we notice that very few students succeed in S1 and S2. Moreover, this case never occurs among pupils who do not study ISI.

In each situation (which confirms that this behaviour is persistent among "novices"), we see that all those who wrongly approved the invariance flow despite an increase in pressure drop, also believe that this flow is continuous and regular. As Blondin et al. pointed out *"Everything happens as if pupils improperly applied the same rule to both situations (...). The consistency of the flow in a same series circuit is incompatible with the recognition of the generalised decrease in flow linked to the increase in loss of charge"*.

In contrast, although they are few in number, 10% of previous ISI pupils are able to avoid this incorrect generalisation by providing correct answers in both situations. This result is positive if we consider that in the experiment by Blondin and al. after initiation with the principles of hydro-dynamics only 2 out of 7 pupils were able to articulate these views.

However, previous ISI pupils also have a tendency to transpose the arguments they use in S1 to justify constant flow (“the flow doesn’t vary, it is the pressure that varies”, “because it is a closed circuit”, “because the pump always has the same flow”, “the section is smaller but the pressure is greater, which compensates for that”) and explain its remaining the same in S2 after making the pipe narrower.

Thoughts on the electricity problem (P2)

The principle of the electrical circuit presented to pupils is the same as in the previous problem but now with a generator and a resistance included in the circuit.

Intensity of the current at different points in a series circuit (S1)

According to the distribution of answers observed (table 3), opinions in favour of the conservation of current intensity seem slightly more common among pupils in year 12 classes having ISI compared to those who haven’t studied industrial systems. But the tendency is the opposite in year 13, giving an advantage to scientific pupils. However, these differences are not significant.

answers Type	intensity answer in A and B	Year 12 c		Year 13	
		with ISI	without ISI	with ISI	without ISI
1	A = B	57	38	48	60
2	A > B	41	62	48	40
3	A < B	2	0	4	0
Total		100%	100%	100%	100%
N Pupils		58	16	31	10

Table 4: Distribution (%) of answer types about the comparison of the intensity at points A and B

These points of view expressed in favour of maintaining intensity inside the electric circuit are justified either by comments like “the intensity is identical at every point in a series circuit” or by the formula “ $U= RI$ “. Hence, they seem to be induced directly from school knowledge. This is not surprising if we remember that the notion of electric circuits is introduced in elementary lessons before being learnt in greater depth in middle school. In comparison with commentaries used for items in 1.1, we see a notable difference in terms of the words used – the term “circuit” comes back all the time in this instance, whereas it was rarely applied to the hydraulic system.

The influence of knowledge learnt at school is also highlighted when comparing the percentages of correct answers (type 1) recorded for each problem. Indeed, it appears that judgments in favour of a constant current intensity are systematically higher (from 20 to 30%) than those favouring a constant flow. Nevertheless, the natural tendency to adopt a sequential thinking is still very common. The majority (62%) of year 11 non ISI pupils affirm that current intensity is lower further down from resistance than further up (response 2) because the resistance “takes a little bit of current “, “retains some of the electrons”, “there isn’t a bulb in the circuit”, or “because A is situated next to the positive terminal” or “because the intensity at A is equal to that of the generator “.

These sequential reasoning are lesser amongst the ex ISI pupils (41% in year 12 and 48% in year 13) and S year 13 pupils (40%), but these are simple trends. Moreover, if we compare the frequency of these answers to that which favours a reduction in flow at the narrowed point, we see quite similar results (previously 62% versus 69% for year 12 non ISI pupils; 41% compared to 48% for year 12 with ISI; 48% versus 45% for year 13 with ISI and 40% on both sides for year 13 S pupils). This could lead us to believe that the majority of pupils adopt the same way of thinking for both circuits.

However, an individual analysis of answers contradicts such stability. Indeed, looking first at the ex ISI pupils, we see that of the 71 pupils who think that the flow varies at different points in the hydraulic circuit, there are 31 of them (practically half !) who on the other hand favour a constant current intensity between points A and B. This could be easily explained (by the influence of notions of electricity) if we did not also see a change in opinion on behalf of those who appeared to master the constancy of the flow. However, of the 28 pupils answering that the narrowing does not alter the flow in the hydraulic circuit, 11 estimate that the resistance value modifies the intensity in the electrical circuit.

We see the same phenomenon with non ISI pupils. However, the proportion of pupils who succeed with S1 in each domain appears greater for pupils who have studied technical systems. Moreover, this consistency in

points of view is proportionally greater (one student on two) among pupils who studied SI than for those who abandoned technology learning (one student on eight).

The major instability in the points of view adopted with both circuits can be explained with regard to the French concept of “didactic contract” (Brousseau, 1997). Unaccustomed to being successively faced with problems with a strong analogy, it is indeed possible that pupils tended to perceive this similarity between the two situations as a trap to be avoided. In other words, the analogy between the two problems having been too obvious, the pupils thought that the two problems required different solutions.

The second difficulty with this inconsistency is more troublesome. Indeed, the inability to transfer correct reasoning to isomorphic tasks may also indicate a lack of confidence that students have in their knowledge. So, as we have seen, with the exception of half ISI + SI pupils, very few pupils seem to have an expansive and ensured systemic conception of closed circuits.

Intensity of the current at different points of a series circuit after an increase in the loss of charge (S2)

After increasing the resistance value (table 4), only around a third of the pupils express points of view in favour of lower intensity up and down the modification (answers of type 1) introduced in the circuit. But only 14% of non ISI pupils in year 12 gave this correct pattern of answers. However, these percentages are once again higher than those of type 1 responses obtained for S2 in hydro-dynamics (moving notably from 0 to 30% correct answers for scientific year 13, and from 0 to 14% correct answers for year 12 non ISI pupils).

Types of answers	Comparison with the intensity measured at the same point before R increase		Year 12		Year 13	
	In A	In B	with ISI	without ISI	with ISI	without ISI
1	-	-	29	14	32	30
2	=	=	17	22	10	20
3	=	-	45	57	39	30
4	=	+	2	0	0	0
5	+	-	0	7	16	0
6	+	+	0	0	0	10
7	+	=	2	0	0	0
8	-	+	2	0	0	0
9	-	=	3	0	3	10
Total			100%	100%	100%	100%
N pupils			58	14	31	10

Table 5: Distribution (%) of types of answer on the comparison of intensity after an increase in loss of charge (Nota: “- ; =; +” respectively means that intensity is considered inferior, equal or higher than it was before the resistor increase)

Moreover, here we observe that it is easier for students to consider that the conservation of intensity in S1 is consistent with the decrease in S2 at points A and B. Indeed, in the previous problem (P1) only 10% of ex ISI students succeed in both situations. On the contrary, here this combined success is achieved by all pupils who solve S2 correctly (with 3 exceptions). In P2 (electro-kinetics problem) correct answers at S1 and S2 are given by 26% of ISI and 14% of non ISI pupils in year 12, and 32% of ISI and 20% of non ISI pupils in year 13. Hence, the electrical circuit generates more correct answers than the hydraulic circuit – both on the conservation of intensity inside a series circuit, and on the generalised decrease of this intensity following an increase in lost charge. Here, the constant intensity reasoning (response 2) is made by 10% of former ISI pupils in year 13, and 20% of pupils in the other groups. This misconception is therefore no longer dominant anywhere. Compared with the previous problem, this opinion is on the decline everywhere except for year 12 non ISI pupils. Arguments similar to those used for P1 are used to justify these answers: “Only the tension changes, not the intensity”, “We did not change the generator power”, “The generator still produces the same amount of electrons”. As before, we also see that all pupils who adopt this type of reasoning think at the same time that the intensity is identical at every point in a series circuit. For example, this means that for year 12 non ISI pupils, half of those who affirm that the intensity is equal in the whole circuit also think that the intensity is maintained in S2 after the circuit has been modified. However, this proportion is lower in the other groups. Although the electrical circuit leads to fewer errors than the hydraulic one, one difficulty remains, especially for pupils who appear to be the most novices. For them, the stability of a parameter within a system seems inconsistent with the variability of this parameter from one system to another.

For most pupils, increasing the resistance only changes the intensity at point B, meaning downstream from the place where it is situated. However, this point of view is slightly less common among year 13 pupils (39% compared to 45% for year 12 ex ISI and 30% versus 57% for year 12 non ISI pupils). The numerous references to the location of R are clear with regard to the sequential nature of the reasoning used. But a large number of these answers are also justified by the formula " $I = U/R$ so if R increases, I decreases" as if it only applied to certain parts of the circuit.

It should be pointed out that we no longer find any clear differences here between answers given by pupils who have studied engineering sciences (SI) and those only having studied the 'basics' (ISI). In other words, the effect of ISI and of ISI supplemented by the SI option appears less clearly when the problem is more familiar to all pupils, as is the case here.

Conclusions

In keeping with lots of education studies preoccupied with looking at the pupils' types of reasoning used in different areas of physics problems, Blondin, Closset and Lafontaine (1990, 1992) have highlighted, with regard to hydraulic circuits, that novice pupils tend to use local or sequential views like those described for electric circuits.

Given that these circuits instead require a systemic kind of understanding, it seemed interesting to see whether ex ISI (initiation to engineering sciences) pupils were capable of a more relevant approach to these problems. Indeed, in this option and in the SI (engineering sciences) option (taught after in year 12 and year 13 classes) pupils learn all the concepts (overall finality, holistic approach, input and output, cycle, feed-back, relationships among parts,...) related to the understanding of structure and functioning of systems.

Our results show that such instruction seems to promote, with regard to the hydraulic circuit, an evolution of the conceptions with a reduction in 'local' points of view, to the benefit of sequential reasoning, and especially ones about conserving flux (first situation). However, this positive impact only seems to be short-term, unless this effect is enhanced by a continuation of this teaching (SI) in year 12 and 13.

Concerning the generalised decrease in consecutive flow to an increased loss of charge within the circuit, the results of the second situation (S2) also seem to generate progress: the teaching of ISI + SI facilitates, for certain pupils, the transfer of a systemic reasoning to new situations, whereas for others students, it contributes to destabilising the habitual naive approach. Moreover, some ex ISI pupils manage to combine the points of view required for each of the two situations, contrary to the trend which usually leads pupils having accessed the idea that flow is conserved in space (in the different points of the same circuit) to consider incorrectly that the flow is also invariant over time (at the same points before and after altering the circuit).

However, the second problem (P2) in the domain of electro-kinetics problem (P2), allowed us to note the unstable nature of the points of view adopted when students are faced with analogous circuits. Nevertheless, the combined success for the both situations is easier here, because of the greater familiarity with this area of knowledge. In the same way, this greater familiarity with the electricity domain explains why the positive impact of ISI is less obvious in the case of hydro-dynamics, because this topic is not taught at secondary school.

However, we must remain cautious about the significance of the findings highlighted in this paper. Indeed, this study has several limitations. First of all, it is possible that the effects observed are in part related to the ISI teacher and to the school whose students come from. Indeed, each teacher has its own way to approach the topics of the curriculum and all the ISI students of our sample were taught by the same teacher. It is also interesting to note that this teacher has extensive experience in technology and design education and contributed to the implementation of the option ISI in France. As we have also said, all the pupils come from the same school, and this establishment is particular in that it offers a complete technological study courses which confers to the ISI option a large influence in future determining the students' orientations.

Secondly, the variation between the students' responses can be due to differences in students' ability levels. Most students who choose the ISI option in year 11 plan to continue after in a scientific section. Thus, it is possible that these students are more advanced academically than those who opt for an economical and social sciences option which they were compared. In order to limit this type of bias, we however avoided making a comparison with students whose profile is literary. Anyway, these results would be confirmed in other populations and in better conditions than those used in this study.

The study of pupils' ability to transfer knowledge acquired in one area into another domain constitutes a crucial issue for educational research and more especially in technology education. Indeed, technology education must continue to show that it contributes to the conceptual development and cognitive. We hope to contribute in this paper.

References

- Andreucci, C. (2006). La fabrication d'artefacts comme moyen didactique de conceptualisation de la réalité technique. *Aster*, 41, 153-184.
- Andreucci, C. (2008). The structuring role of artefacts in thought development. In J. Ginestí (Ed.), *The cultural transmission of artefacts, skills and knowledge. Eleven studies in technology education* (pp. 21-41). Rotterdam: Sense Publishers.
- Barak, M. (1990). Imparting basics in technology through an instructional system for computerized process control. *Research in Sciences and Technology Education*, 8 (1), 53-67.
- Barak, M. & Williams, P. (2007). Learning elemental structure and dynamic processes in technology systems: A cognitive frameworks. *International Journal of Technology and Design Education*, 17, 323-340.
- Bertalanffy, L. von. (1968). *Organismic Psychology and systems theory*. Worchester: Clark University Press.
- Blondin, C., Closset, J.L. & Lafontaine, D. (1990). Résolution de problèmes d'hydrodynamique face à un circuit concret - Comparaison des stratégies avant et après apprentissage. *European Journal of Psychology of Education*, 5 (4), 517-531.
- Blondin, C., Closset, J.L. & Lafontaine, D. (1992). Raisonnements naturels en hydrodynamique. *Revue Française de Pédagogie*, 100, 71-80.
- Brown & al. (1989). Situated cognition and the culture of learning. *Educational Research*, 18 (1), 32-42.
- Brousseau, G. (1997). *Theory of Didactical Situations in Mathematics: didactiques des mathématiques, 1970-1990*, N. Balacheff, M. Cooper, R. Sutherland, V. Warfield (Trans.), Dordrecht: Kluwer.
- Chatoney, M., (2005). Activités de production et construction du concept de matériau en réalisation sur projet en classe de CP. In P. Vérillon P., J. Ginestí et al. (Eds.), *Produire en technologie à l'école et au collège*, (pp. 279-306), Paris: INRP.
- Chatoney, M. (2006). Organiser les activités de production à l'école primaire – Sélectionner des matériaux avec des élèves de 6 ans. *Aster*, 41, 139-158.
- Chevallard, Y. (1995). *La transposition didactique: du savoir savant au savoir enseigné*. (2^{ème} Ed.). Grenoble: la Pensée Sauvage.
- Closset, J.L. (1989). Les obstacles à l'apprentissage de l'électrocinétique. *Bulletin de l'union des physiciens*, 716, 931-950.
- Deforge, Y. (1985). *Technologie et génétique de l'objet industriel*. Paris: Maloine.
- Dubois, S. & Gartiser, N. (2005). L'impact du concept de problème sur son processus de résolution. Application à la conception de systèmes techniques. *Actes du 6^e congrès international de génie industriel*, 7-10 juin, Besançon.
- Dorst K. (2006). Design problems and design paradoxes, *Design Issue*, 22 (3), 4-17.
- de Rosnay, J. (1975). *Le microscope*. Paris: Seuil.
- de Vries, M. (2005). *Teaching about technology*. Dordrecht: Springer.
- Froment, J.P. (2002). La valeur du schéma cinématique en tant qu'artéfact cognitif. *Didaskalia*, 21, 43-80.
- Gille B. (1978). *Histoire des techniques*. Paris: Gallimard.
- Ginestí, J. (1992). Contribution à la didactique des disciplines technologiques: acquisition et utilisation d'un langage d'automatisme. *Thèse de doctorat de l'Université de Provence (mention sciences de l'éducation)*. Aix-en-Provence: France.
- Ginestí, J. (2008). Gestepro, a research laboratory in science, technology and vocational education. In J. Ginestí (Ed.), *the cultural transmission of artefacts, skills and knowledge: Eleven studies in technology education* (pp. 3-6). Rotterdam: Sense Publishers.
- Inhelder, B., & Cellier, G. (1992). *Les chemins de la découverte chez l'enfant*. Paris: Delachaux & Niestlé.
- Joshua, S. & Dupin J.J. (1993). *Introduction à la didactique des sciences et des mathématiques*. Paris: PUF.
- Lebahar, J.C. (2006). Pratiques professionnelles et enseignement de la technique d'organigramme en architecture: problèmes de transposition didactique. *Didaskalia*, 29, 9-40.
- Lebeaume, J. (2000). *L'éducation technologique. Histoire et méthode*. Paris: ESF.
- Lemoigne, J.L., (1990). *La modélisation des systèmes complexes, EFCE system*, Paris: Dunod.
- Martinand, J.L. (2003). L'éducation technologique à l'école moyenne en France: Problèmes de didactique curriculaire. *Revue canadienne de l'enseignement de sciences des mathématiques et des technologies*, 3 (1), 101-106.
- BOEN, Bulletin officiel du ministère de l'éducation nationale et du ministère de la recherche, (2001), 8, HS du 31 aout. www.education.gouv.fr/bo/2001/hs2/seconde2.htm
- Morin E., 1990. *Introduction à la pensée complexe, Communication et complexité*. Prague: ESF.
- Simon, H.A. (1991). *Sciences des systèmes, sciences de l'artificiel*. Paris: Dunod.
- Tiberghien, A. (2003). Des connaissances naïves au savoir scientifique. In M. Kail & M. Fayol (Eds.), *Les sciences cognitives et l'école. La question des apprentissages* (pp. 333-443). Paris: Presses Universitaires de France.

Viennot, L. (2006). Modélisation dimensionnellement réductrice et traitement particulière dans l'enseignement de la physique. *Didaskalia*, 28, 6-32.