



HAL
open science

Sliding Mode Current Controllers Combined with Single Input Fuzzy Logic Voltage Controllers to Regulate Asynchronous Wind Turbine Output Terminals Using STATCOM

Mohammed Mokhtari, Smail Zouggar, Nacer K M'Sirdi, M L Elhafyani1

► To cite this version:

Mohammed Mokhtari, Smail Zouggar, Nacer K M'Sirdi, M L Elhafyani1. Sliding Mode Current Controllers Combined with Single Input Fuzzy Logic Voltage Controllers to Regulate Asynchronous Wind Turbine Output Terminals Using STATCOM. 21st IFAC World Congress, Jul 2020, Berlin, Germany. hal-02492457

HAL Id: hal-02492457

<https://hal-amu.archives-ouvertes.fr/hal-02492457>

Submitted on 27 Feb 2020

HAL is a multi-disciplinary open access archive for the deposit and dissemination of scientific research documents, whether they are published or not. The documents may come from teaching and research institutions in France or abroad, or from public or private research centers.

L'archive ouverte pluridisciplinaire **HAL**, est destinée au dépôt et à la diffusion de documents scientifiques de niveau recherche, publiés ou non, émanant des établissements d'enseignement et de recherche français ou étrangers, des laboratoires publics ou privés.

Sliding Mode Current Controllers Combined with Single Input Fuzzy Logic Voltage Controllers to Regulate Asynchronous Wind Turbine Output Terminals Using STATCOM

Mohammed MOKHTARI*, Smail ZOUGGAR*, Nacer K M'SIRDI**, M.L Elhafyani1**

*University Mohammed 1st, School of Technology, Laboratory of Electrical Engineering and Maintenance (LEEM)
60000 Oujda, Morocco (mohammed.mokhtari@outlook.com)

**LSIS, CNRS UMR 6168. Dom. Univ. St Jrme, Av. Escadrille Normandie - Niemen 13397.
Marseille Cedex 20. France (nacer.msirdi@univ-amu.fr)

Abstract: This paper demonstrate the fiability and the efficiency of a proposed control law based on a combination of a sliding mode current controllers and a single input fuzzy logic controller, used to command a static synchronous compensator in order to improve voltage profile and stability of an asynchronous wind turbine despite wind speed and load variation. All simulation results as well as the modeling of the wind power system and the design of the proper controllers are described in detail in this document.

Keywords: Asynchronous Wind Turbine; STATCOM; Voltage Regulation; Single Input Fuzzy Logic Controller; Sliding Mode Controllers.

NOMENCLATURE

ρ	Air density.
R	Blades length.
V	Wind Speed.
$C_p(\lambda)$	Aerodynamic performance of the turbine.
Ω_{turb}	Turbine shaft speed.
C_g	Transmitted torque to the shaft of the IG
C_{aer}	Aerodynamic torque.
M	Multiplier ratio.
Ω_{mec}	Mechanical speed of the IG shaft
ω_r	Induction generator shaft angular velocity.
V_{sd}, V_{sq}	Stator terminal voltages in dq reference.
i_{sd}, i_{sq}	Stator phase current in dq reference.
i_{rd}, i_{rq}	Rotor phase current in dq reference.
$\varphi_{rd}, \varphi_{rq}$	Rotor flux in dq reference.
$\varphi_{sd}, \varphi_{sq}$	Stator flux in dq reference.
R_r, R_s	Per phase rotor and stator resistances.
L_m	Magnetizing reactance.
l_s, l_r	Stator and rotor leakage reactances.
ω_s	Synchronous angular velocity.
V_{otd}, V_{otq}	STATCOM voltage in dq reference.
i_{otd}, i_{otq}	STATCOM current in dq reference.

1. INTRODUCTION

In the last decades, the use of renewable energy sources has increased considerably in rural areas, mainly those in hilly and remote regions. Often, an isolated asynchronous wind turbine is the best solution to choose to eliminate the high-cost investment required for transmission line by conventional system.

However, it is well known that reactive power management is the greatest challenge in asynchronous wind turbine based on a three-phase Self-Excited Induction Generator (SEIG) [1] [2]. Any variation of wind speed or load causes a variation on the needed reactive power and thus a voltage fluctuation. Flexible AC transmission (FACT) device such as STATCOM become then a necessity to prevent voltage instability and hence voltage collapse at the point of common coupling (PCC) [3] [4] [5].

Basically, there are two control objectives implemented in STATCOM. One is the PCC voltage regulation and the other is DC voltage regulation across its capacitor [6]. In conventional scheme, a decoupled dq axis control approach based on four proportional integral (PI) type cascaded controllers is used [7]. Aside from experimental procedures, to the authors' knowledge, there is no standard procedure for designing the ac voltage regulator that ensures the required stability and robustness to system variations. In general, the chosen set of PI gains remain fixed in daily operation of STATCOM. Since wind speed and load changes with time those parameters may not be suitable for all operating points [8]. Therefore, to reduce voltage fluctuation at all possible conditions we propose a new structure based on a combination

of a sliding mode current controller and a single input fuzzy logic controller for ac voltage regulation [9] [10].

The organization of this paper is as follows. It starts with the modelling of the studied asynchronous wind turbine and STATCOM, then focuses on the description of the proposed control scheme and the design of the proper regulators, to finally discuss and analysis the simulated results.

2. SYSTEM DESCRIPTION

The block diagram of the studied system is shown in Fig. 1. It consists of a three-bladed wind turbine driving a self-excited induction generator through a speed gain multiplier M and a static synchronous compensator for voltage regulation.

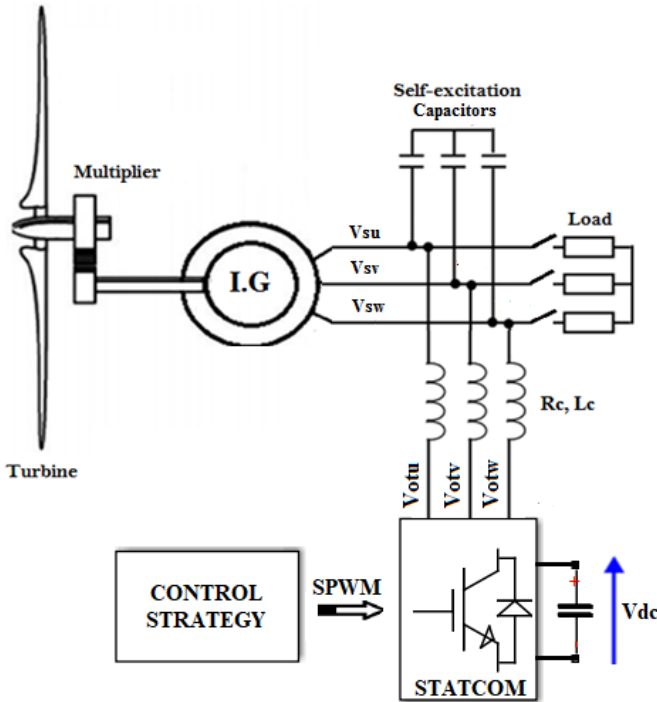

Fig. 1. Wind energy conversion system diagram

2.1 Wind Turbine Modelling

The aerodynamic power P_{aer} extracted from the wind turbine along with the aerodynamic torque are expressed through the following relations respectively:

$$P_{aer} = C_p(\lambda) \cdot \frac{\rho \cdot \pi \cdot R^2 \cdot V^3}{2} \quad (1)$$

$$C_{aer} = \frac{P_{aer}}{\Omega_{turb}} = C_p(\lambda) \frac{\rho \cdot \pi \cdot R^2 \cdot V^3}{2 \cdot \Omega_{turb}} \quad (2)$$

2.2 Multiplier

The torque and the mechanical speed transmitted from the wind turbine to the shaft of the induction generator are:

$$C_g = \frac{C_{aer}}{M} \quad (3)$$

$$\Omega_{mec} = \frac{\Omega_{turb}}{M} \quad (4)$$

2.3 Self-Excited Induction Generator Modelling

The mathematical model of the asynchronous generator in dq reference frame is described as follows:

$$V_{sd} = R_s \cdot i_{sd} + \frac{d\phi_{sd}}{dt} - \omega_s \cdot \phi_{sq}$$

$$V_{sq} = R_s \cdot i_{sq} + \frac{d\phi_{sq}}{dt} + \omega_s \cdot \phi_{sd} \quad (5)$$

$$V_{rd} = 0 = R_r \cdot i_{rd} + \frac{d\phi_{rd}}{dt} + (\omega_s - \omega_r) \cdot \phi_{rq}$$

$$V_{rq} = 0 = R_r \cdot i_{rq} + \frac{d\phi_{rq}}{dt} - (\omega_s - \omega_r) \cdot \phi_{rd}$$

$$\phi_{sd} = L_s \cdot i_{sd} + L_m \cdot i_{rd}$$

$$\phi_{sq} = L_s \cdot i_{sq} + L_m \cdot i_{rq} \quad (6)$$

$$\phi_{rd} = L_m \cdot i_{sd} + L_r \cdot i_{rd}$$

$$\phi_{rq} = L_m \cdot i_{sq} + L_r \cdot i_{rq}$$

The dynamic equation of the mechanical motion can be given as:

$$J_t \frac{d\Omega_{mec}}{dt} = C_g - C_{em} - f_{vis} \cdot \Omega_{mec} \quad (7)$$

Where:

$$C_{em} = p \cdot \frac{L_m}{L_r} (\phi_{rd} \cdot i_{sq} - \phi_{rq} \cdot i_{sd}) \quad (8)$$

$$J_t = \frac{J_{turb}}{M^2} + J_g \quad (9)$$

The self-priming of the induction generator is done via a capacitive bench, if connected to a resistive load R they are represented by the following equations in dq reference frame:

$$\frac{dV_{sd}}{dt} = \frac{-1}{C_{ext}} \cdot i_{sd} - \frac{1}{RC_{ext}} \cdot V_{sd} \quad (10)$$

$$\frac{dV_{sq}}{dt} = \frac{-1}{C_{ext}} \cdot i_{sq} - \frac{1}{RC_{ext}} \cdot V_{sq} \quad (11)$$

2.4 STATCOM Modelling

The equations describing the AC side of STATCOM in the synchronous reference frame are given by:

$$\frac{d}{dt} \begin{bmatrix} i_{otd} \\ i_{otq} \end{bmatrix} = \begin{bmatrix} -\frac{R_c}{L_c} & \omega_s \\ \omega_s & -\frac{R_c}{L_c} \end{bmatrix} \begin{bmatrix} i_{otd} \\ i_{otq} \end{bmatrix} + \frac{1}{L_c} \begin{bmatrix} V_{sd} - V_{otd} \\ V_{sq} - V_{otq} \end{bmatrix} \quad (12)$$

Where ω_s the pulsation of the generated voltage V_s .

The voltage and current are related in the DC side of STATCOM by the following equation:

$$\frac{dV_{dc}}{dt} = \frac{i_{dc}}{C_{dc}} \quad (13)$$

Since SPWM technique is used in STATCOM, and all the voltage harmonics produced by the inverter are neglected, the equations relating the dc-side and ac-side can be written as:

$$\begin{bmatrix} V_{otd} \\ V_{otq} \end{bmatrix} = MI \cdot V_{dc} \cdot \begin{bmatrix} \cos(\alpha) \\ \sin(\alpha) \end{bmatrix} \quad (14)$$

$$i_{dc} = MI \cdot [i_{otd} \quad i_{otq}] \cdot \begin{bmatrix} \cos(\alpha) \\ \sin(\alpha) \end{bmatrix} \quad (15)$$

Where MI the Modulation Index and α the firing angle are the control variables of STATCOM, deduced from the voltage references by:

$$MI = \frac{\sqrt{V_{otd_ref}^2 + V_{otq_ref}^2}}{V_{dc}} \quad (16)$$

$$\alpha = \tan^{-1}\left(\frac{V_{otq_ref}}{V_{otd_ref}}\right) \quad (17)$$

3. CONTROL STRATEGY

In order to improve the performance of the asynchronous wind turbine, STATCOM will exchange reactive power with the SEIG to reduce the AC voltage fluctuation and will absorb active power to keep the DC voltage at its rated value.

In dq coordinate, each of the current components has clear physical meaning. As we can see from (18) the d-axis current component i_{otd} contributes to the control of the instantaneous active power $P(t)$, while the q-axis one i_{otq} contributes to the control of the instantaneous reactive power $Q(t)$:

$$P(t) = \frac{3}{2} v_{sd} i_{otd} \quad (18)$$

$$Q(t) = -\frac{3}{2} v_{sd} i_{otq} \quad (19)$$

From (12) both components of the current are cross-coupled through the term $\omega_s L_c$. The decoupling of the active and reactive current become then necessary. In this work the classical decoupled watt-var method is used. The two new variables introduced in (20) and (21) represent the output from the control system.

$$V_{otd}^* = i_{otq} \omega_s L_c + V_{sd} - V_{otd_ref} \quad (20)$$

$$V_{otq}^* = i_{otd} \omega_s L_c + V_{sq} - V_{otq_ref} \quad (21)$$

The adopted control strategy contains two loops. In the first loop, the outer loop, the AC voltage of the asynchronous generator terminals and the DC voltage of STATCOM should be regulated to their reference values via a single input fuzzy logic controller and a sliding mode controller respectively, Fig. 2. In the second loop, inner loop, the injected currents i_{otd} and i_{otq} are adjusted in order to follow their reference values i_{otq}^* and i_{otd}^* using also a sliding mode controllers, Fig. 3.

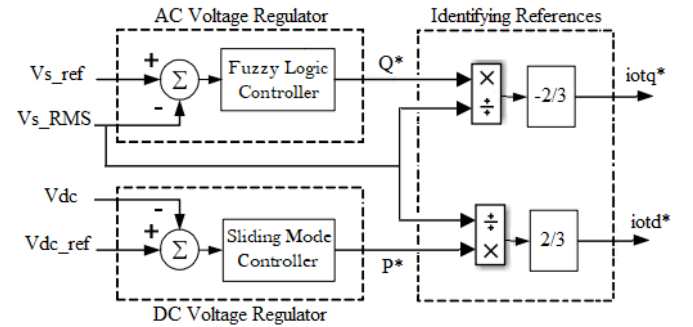

Fig. 2. Outer loop of voltage control

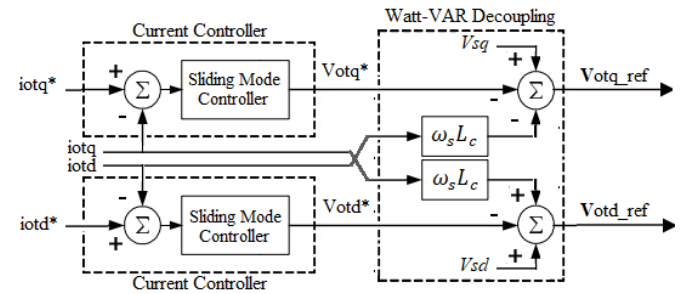

Fig. 3. Inner loop of current control

3.1 Current controller design

- Sliding Surface:

The control objectives are to track or slide along the predefined current components references i_{otd}^* . For this purpose, the sliding surfaces are set as:

$$S_d = i_{otd} - i_{otd}^* \quad (22)$$

$$S_q = i_{otq} - i_{otq}^* \quad (23)$$

The sliding surfaces derivatives are given respectively as:

$$\frac{dS_d}{dt} = -k_d \text{sign}(S_d) \quad (24)$$

$$\frac{dS_q}{dt} = -k_q \text{sign}(S_q) \quad (25)$$

Where k_d and k_q are positive constants.

However, from (22) and (23) we have:

$$\frac{dS_d}{dt} = \frac{di_{otd}}{dt} - \frac{di_{otd}^*}{dt} \quad (26)$$

$$\frac{dS_q}{dt} = \frac{di_{otq}}{dt} - \frac{di_{otq}^*}{dt} \quad (27)$$

From (12), (20) and (21), we can write:

$$\frac{di_{otd}}{dt} = -\frac{R_c}{L_c} i_{otd} + \frac{V_{otd}^*}{L_c} \quad (28)$$

$$\frac{di_{otq}}{dt} = -\frac{R_c}{L_c} i_{otq} + \frac{V_{otq}^*}{L_c} \quad (29)$$

Thus, STATCOM voltage references are calculated as follow:

$$V_{otd.n}^* = -L_c k_d \text{sign}(S_d) + R_c i_{otd} \quad (30)$$

$$V_{otq.n}^* = -L_c k_q \text{sign}(S_q) + R_c i_{otq} \quad (31)$$

When the sliding mode occurs on the sliding surface, then $S_{dq} = \dot{S}_{dq} = 0$, and therefore the dynamic behaviour of the tracking problem is equivalently governed by the following equations:

$$\frac{dS_d}{dt} = \frac{di_{otd}}{dt} - \frac{di_{otd}^*}{dt} = -\frac{R_c}{L_c} i_{otd} + \frac{V_{otdeq}^*}{L_c} = 0 \quad (32)$$

$$\frac{dS_q}{dt} = \frac{di_{otq}}{dt} - \frac{di_{otq}^*}{dt} = -\frac{R_c}{L_c} i_{otq} + \frac{V_{otqeq}^*}{L_c} = 0 \quad (33)$$

So, we can write:

$$V_{otdeq}^* = R_c i_{otd} \quad (34)$$

$$V_{otqeq}^* = R_c i_{otq} \quad (35)$$

Finally, the sliding mode current controllers are designed as:

$$V_{otd}^* = V_{otdn}^* + V_{otdeq}^* \quad (36)$$

$$V_{otd}^* = -L_c k_d \text{sign}(S_d) + R_c i_{otd} + R_c i_{otd}$$

$$V_{otq}^* = V_{otqn}^* + V_{otqeq}^* \quad (37)$$

$$V_{otq}^* = -L_c k_q \text{sign}(S_q) + R_c i_{otq} + R_c i_{otq}$$

- Stability analysis:

A Lyapunov function is necessary so that the existence of the sliding mode is determined. It is defined by the following expression:

$$V = \frac{1}{2} S_d^2 + \frac{1}{2} S_q^2 \quad (38)$$

To guarantee the attraction of the system throughout the surface, the following condition must be respected:

$$\dot{V} < 0 \quad (39)$$

By differentiating (38), we have:

$$\dot{V} = S_d \dot{S}_d + S_q \dot{S}_q \quad (40)$$

Replacing (24) and (25) into (40), we obtain:

$$\dot{V} = -S_d k_d \text{sign}(S_d) - S_q k_q \text{sign}(S_q) \quad (41)$$

It results:

$$\dot{V} = -k_d |S_d| - k_q |S_q| < 0 \quad (42)$$

Consequently, we have proved that the global asymptotical stability is ensured.

3.2 AC voltage controller design

The proposed controller is constructed by choosing the error between the reference and the measured RMS value of the asynchronous wind turbine generated voltage as an input signal and dQ^* as output signal, Fig.4.

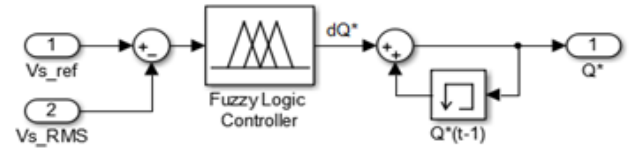

Fig. 4. AC voltage regulator

The reference reactive power to exchange with the induction generator in order to maintain the AC voltage stable is calculated using the following expression:

$$Q^* = \sum dQ^*(t) \quad (43)$$

- If error is equal to zero then V_{s_RMS} is equal to V_{s_ref} value, dQ^* must be equal to zero to keep Q^* at its previous value to avoid injection or absorption of any reactive power.
- If error is negative then V_{s_RMS} is greater than V_{s_ref} value (inductive mode), dQ^* must be positive as well as Q^* and its value should increase to absorb the excess of reactive power forcing so the generated voltage to drop to the rated value.

- If error is positive then V_{s_RMS} is less than V_{s_ref} value (capacitive mode), dQ^* must be negative as well as Q^* and its value should decrease to inject the needed reactive power forcing so the generated voltage to rise up to the rated value.

We define a simple structure for the fuzzy controller Mamdani-type with seven triangular rule-based-membership functions. Fig. 5 shows input and output membership functions of the proposed SIFLC.

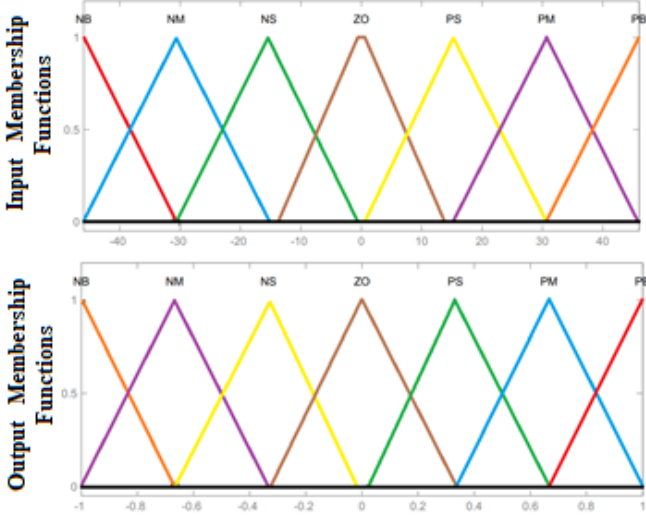

Fig. 5. Inputs and outputs membership functions of the SIFLC

The seven linguistic variables used are Negative Big (NB), Negative Medium (NM), Negative Small (NS), Zero (ZO), Positive Small (PS), Positive Medium (PM) and Positive Big (PB). The 7 rules have been built as represented in Fig. 6.

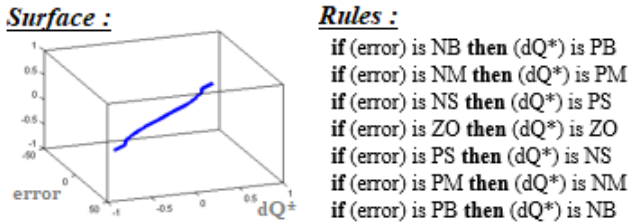

Fig. 6. The chosen rules of the SIFLC

3.3 DC voltage controller design

The active power STATCOM need to absorb from the wind turbine system to compensate losses in the DC circuit is deduced from the following sliding surface:

$$S_p = V_{dc} - V_{dc_ref} \quad (44)$$

The sliding surface derivative is given by:

$$\frac{dS_p}{dt} = -k_p \text{sign}(S_p) \quad (45)$$

Where k_p is a positive constant. From (44) we have:

$$\frac{dS_p}{dt} = \frac{dV_{dc}}{dt} - \frac{dV_{dc_ref}}{dt} \quad (46)$$

However, we know that:

$$\frac{dV_{dc}}{dt} = \frac{i_{dc}}{C_{dc}} = \frac{P_{dc_n}}{C_{dc} \cdot V_{dc}} \quad (47)$$

From (45), (46) and (47) we can write:

$$P_{dc_n} = -k_p \cdot C_{dc} \cdot V_{dc} \cdot \text{sign}(S_p) \quad (48)$$

The expression of the equivalent control laws in this case is null, and can be deduced from (47) by assuming that $\dot{S}_p = 0$:

$$\frac{dS_p}{dt} = \frac{dV_{dc}}{dt} - \frac{dV_{dc_ref}}{dt} = \frac{i_{dc}}{C_{dc}} = \frac{P_{dc_eq}}{C_{dc} \cdot V_{dc}} = 0 \quad (49)$$

So, we can write:

$$P_{dc}^* = P_{dc_n}^* = -k_p \cdot C_{dc} \cdot V_{dc} \cdot \text{sign}(S_p) \quad (50)$$

The stability of the chosen surface for DC voltage control can be verified by following the same method used in sliding surface current controllers.

4. SIMULATION RESULTS & DISCUSSION

Fig. 7 shows the profile of the generated RMS voltage when the asynchronous wind turbine is under varying wind speed and load conditions for both no compensation mode and compensation mode.

During the starting phase from the instant 0s to 2s, STATCOM is not yet connected because the produced voltage has not reached the regulation zone set to $\pm 20\%$ of V_{s_ref} . After the second two, when the single input fuzzy logic controller is connected, V_{s_RMS} reaches 254.4V then drops in 0.5s to 230V which can be considered as a good transient response since the overshoot is around 10%.

At the 4th second and 6th second when wind speed drops from 10.5m/s to 8m/s then rises again to 9m/s at no load, V_{s_RMS} changes also but using the proposed approach STATCOM was capable of regulating the generated voltage in 0.4s and 0.46s respectively.

Finally, when the system become at full load at the 8th second the proposed control strategy have once more proved its efficiency because V_{s_RMS} drops to 183V then stabilizes at the rated value in less than 0.03s.

We can conclude so that using the proposed structure of control, the single input fuzzy logic controller combined with the sliding mode controllers can effectively maintain the self-excited induction generator voltage terminals at its referenced value with good dynamic and static responses.

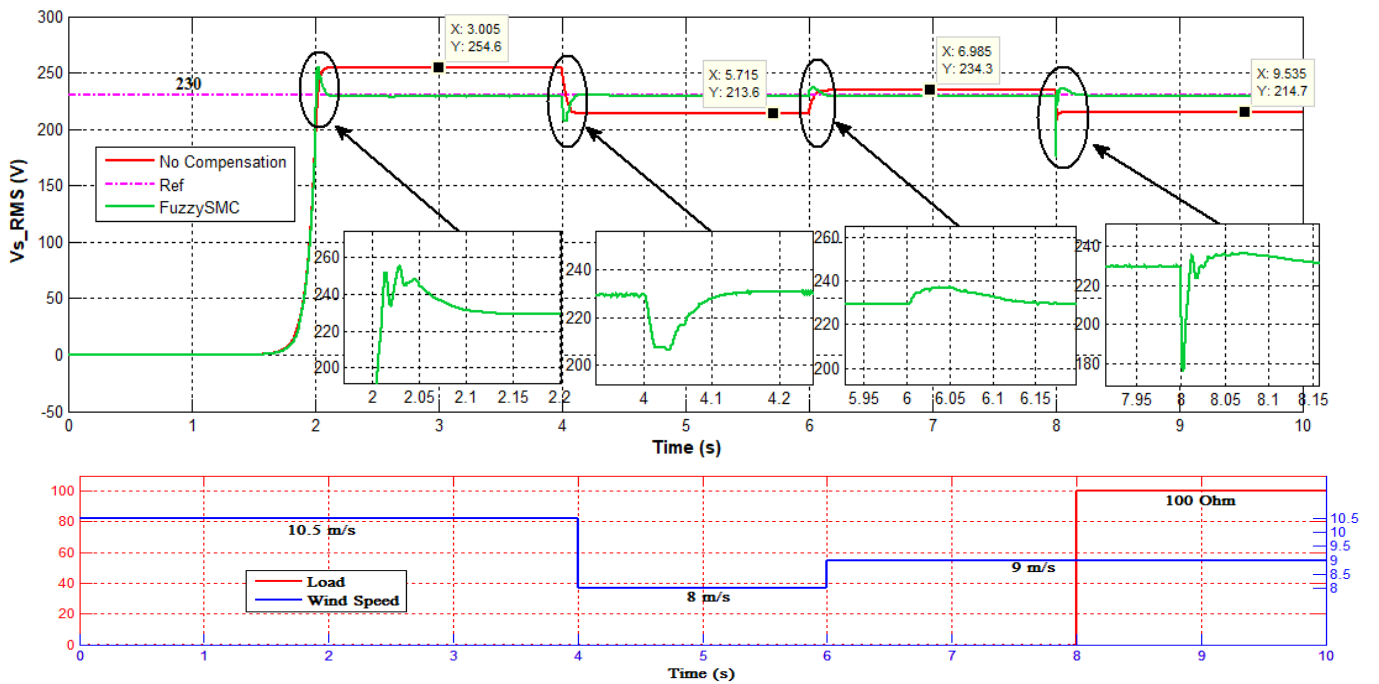

Fig. 7. Asynchronous wind turbine voltage with and without compensation at different wind speed and load state

To be able to reduce AC voltage fluctuations, the SIFLC must respond to wind speed and load variation with a good dynamic forcing so STATCOM to operate in both capacitive and

inductive mode. Fig. 8 shows the exchanged reactive power between the SEIG and STATCOM at different states.

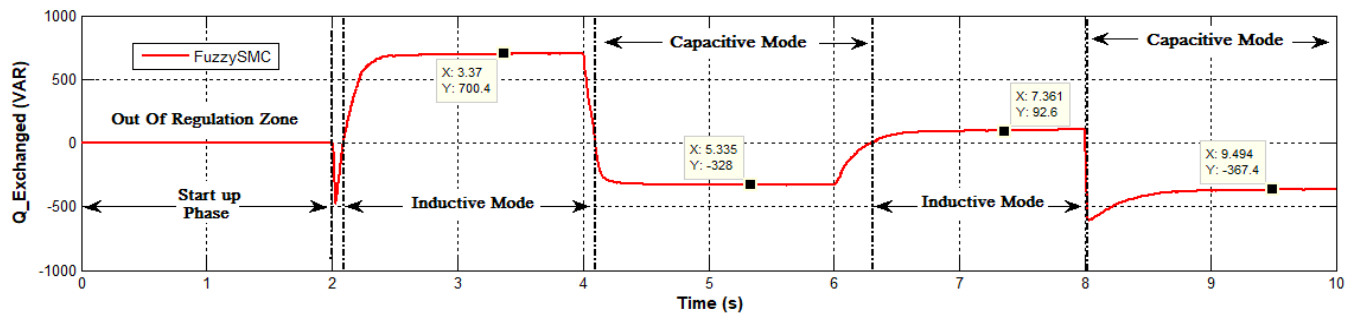

Fig. 8. The exchanged reactive power between STATCOM and the asynchronous wind turbine.

Also, in Fig.9 the injected current i_{otq} that contribute to the control of the reactive power presents a good tracking responses and robust characteristics when the proposed approach is used.

The observed chattering in the steady-state is acceptable due to its small variation and can be reduced in practice by selecting an optimal value of k_q .

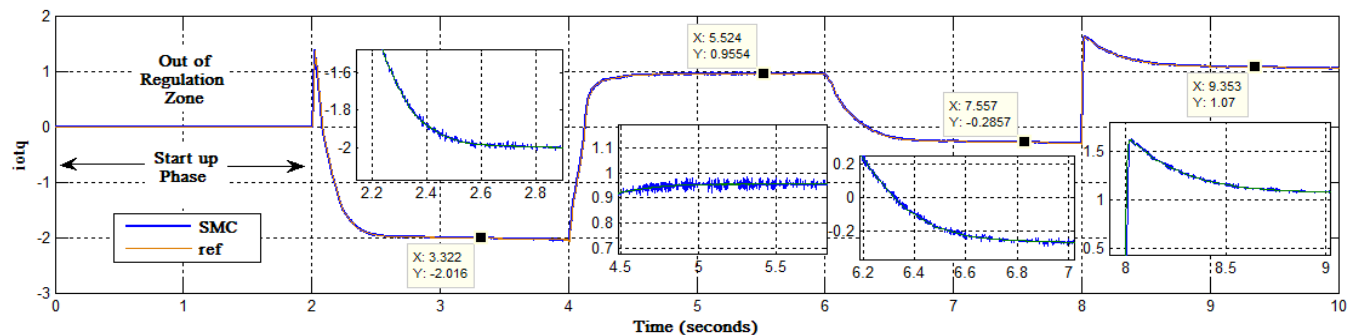

Fig.9. STATCOM q -axis current variation as function of PCC voltage using SMC

In the other part, simulation results observed in Fig.10 shows that the designed sliding mode DC voltage controller was able, at $t=2s$, to rise V_{dc} up to the referenced value just after the excitation of the SEIG.

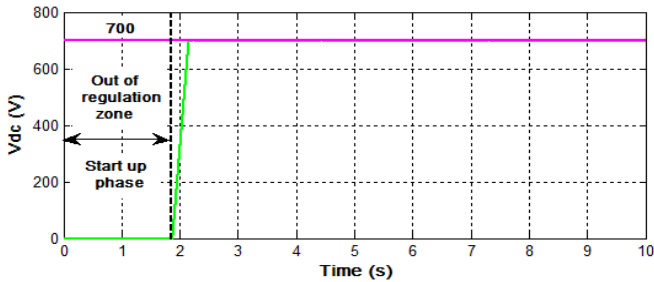

Fig. 10. Sliding Mode DC voltage response

The active power provided by the asynchronous wind turbine to STATCOM to regulated V_{dc} reaches in Fig.11 the value of 28.5W then falls down to zero after 0.7 seconds since all losses are neglected.

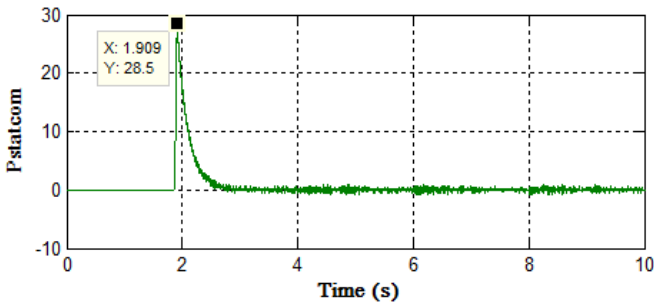

Fig.11. STATCOM absorbed active power

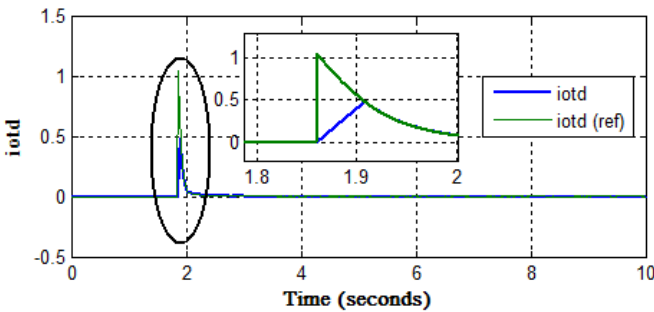

Fig. 12. STATCOM d_axis current variation

The DC voltage controller presents in Fig. 12 a good convergence characteristics which contribute to a good control performance of the active power exchanged between SEIG and STATCOM.

5. CONCLUSION

This paper presented a novel voltage control strategy for asynchronous wind turbine based on STATCOM. The proposed configuration employs single input fuzzy logic and sliding mode approach in order to calculate the required converter's control references so as to eliminate the instantaneous errors of AC and DC voltage. The effectiveness of the current control loops has been first confirmed by the theoretical investigation that proved its convergence. Then the

validity of the proposed voltage control scheme has been established through simulation results analysis that have shown excellent characteristics of voltage profile regarding response time, references tracking, disturbance rejection and robustness.

REFERENCES

- Mokhtari, M., Zouggar, S., Elhafyani, M. L., Ouchbel, T., Benzaouia, S., & Fannakh, M. (2018, April). Design, Simulation and Performance Analysis of Voltage Regulator Based on STATCOM for Asynchronous Wind Turbine. In *International Conference on Electronic Engineering and Renewable Energy*(pp. 498-509). Springer, Singapore.
- Mokhtari, M., Zouggar, S., Elhafyani, M. L., Ouchbel, T., M'sirdi, N. K., & Naaman, A. (2018, December). Voltage Stability Improvement of an Asynchronous Wind Turbine using Static Var Compensator with Single Input Fuzzy Logic Controller. In *2018 6th International Renewable and Sustainable Energy Conference (IRSEC)* (pp. 1-6). IEEE.
- Li, P., Adam, G. P., Holliday, D., & Williams, B. W. (2015, November). High power density STATCOM with extended reactive power control range. In *Renewable Energy Research and Applications (ICRERA), 2015 International Conference on*(pp. 710-715). IEEE.
- Anu, P., Divya, R., & Nair, M. G. (2015, June). STATCOM based controller for a three phase system feeding single phase loads. In *Advancements in Power and Energy (TAP Energy), 2015 International Conference on* (pp. 333-338). IEEE.
- Singh, B., Murthy, S. S., & Chilipi, R. S. R. (2014). STATCOM-based controller for a three-phase SEIG feeding single-phase loads. *IEEE transactions on energy conversion*, 29(2), 320-331.
- Sethy, S. K., & Moharana, J. K. (2012). Design, Analysis and Simulation of Linear Model of a STATCOM for Reactive Power Compensation with Variation of DC-link Voltage. *International Journal of Engineering and Innovative Technology (IJEIT)*, 2(5).
- Jain, A., Joshi, K., Behal, A., & Mohan, N. (2006). Voltage regulation with STATCOMs: Modeling, control and results. *IEEE Transactions on Power delivery*, 21(2), 726-735.
- Perumal, B. V., & Chatterjee, J. K. (2006). Analysis of a self excited induction generator with STATCOM/battery energy storage system. In *Power India Conference, 2006 IEEE* (pp. 6-pp). IEEE.
- Chen, R. B., Zheng, X. M., Pang, S. N., & Li, X. (2017). Based on STATCOM direct current full-order terminal sliding mode control. *The Journal of Engineering*, 2017(13), 2067-2071.
- Mak, L. O., Ni, Y. X., & Shen, C. M. (2000). STATCOM with fuzzy controllers for interconnected power systems. *Electric Power Systems Research*, 55(2), 87-95.
- Farhat, M., Barambones, O., & Sbita, L. (2015). Efficiency optimization of a DSP-based standalone PV system using a stable single input fuzzy logic controller. *Renewable and Sustainable Energy Reviews*, 49, 907-920.